

# INSTRUCTION MANUAL

PELLET BARBECUE

# TABLE OF CONTENTS

<b>01. WARNINGS</b> .....	<b>3</b>
<b>02. EXPLANATION OF DISPLAY AND VARIOUS CONTROLS</b> .....	<b>3</b>
<b>03. HOW TO USE THE BARBECUE CORRECTLY</b> .....	<b>4</b>
<b>04. BARBECUE MAINTENANCE</b> .....	<b>4</b>
<b>05. TROUBLESHOOTING</b> .....	<b>5</b>
<b>06. BARBECUE DEPALLETISING AND ASSEMBLY</b> .....	<b>5</b>
<b>07. SPARE PARTS</b> .....	<b>6</b>
<b>08. WARRANTY</b> .....	<b>7</b>

**IMPORTANT:  
PLEASE READ**

IN ORDER TO AVOID RISK OF FIRE OR MALFUNCTION OF THE APPLIANCE CAUSED BY POOR/INCORRECT MAINTENANCE OR FAILURE TO MAINTAIN THE DISTANCES FROM NON-FLAMMABLE MATERIALS, IT IS ESSENTIAL TO FOLLOW THE INSTRUCTIONS IN THE FOLLOWING MANUAL.

Before using the appliance, a careful reading and understanding of the manual is recommended in order to ensure correct operation of the appliance. It is also advisable to keep the manual in case of future doubts. Failure to follow instructions and use the appliance safely may result in serious injury to persons or property caused by the risk of fire, explosion, suffocation or carbon monoxide poisoning.

Eva Stampaggi S.r.l. assumes no responsibility for damage to persons and/or property or for the malfunction of the fire pit resulting from non-compliance with the provisions of this Instruction Manual.

**HAZARDS AND WARNINGS**

1. Use only natural wood pellets, designed to burn on grills. Do not use fuel labelled as containing additives.
2. Before installation, please inform yourself, through the competent authorities, of any restrictions on the installation of this device in your area.
3. If the grease should catch fire, immediately turn off the barbecue, disconnect from the power supply and close the lid until the flames are reduced. Do not pour water. Don't try to stifle the fire. It may be helpful to keep a fire extinguisher nearby. If, in spite of this, you can't tame the flames, call the fire department.
4. Given the high operating temperatures of the appliance, it is recommended to use gloves with insulating characteristics. For the same reason, do not use flammable materials to cover the barbecue and keep them away from all hot parts. Also make sure to keep children and animals away during operation.
5. The barbecue shall be installed at a minimum distance from burning walls of 1000 mm to the side and 1000 mm to the rear. Do not use indoors, in buildings or other temporary covers. Use only outdoors making sure the environment is ventilated. Do not place near flammable or combustible materials.
6. Keep the pellet and the power cord away from the hot parts of the barbecue. Also protect the barbecue from water and rain, remembering to protect it with a towel when it is stored.
7. Before turning on the barbecue after a long period of inactivity, check the condition of the barbecue. To do this, make sure that there are no impediments in the air and pellet inlet channels. Also make sure that no water or other liquids have come into contact with the tank or electronic components. The company assumes no responsibility in this regard.
8. Before carrying out any manoeuvre to move the barbecue, make sure that it is not running or still hot. Also make sure that the cooking racks and the inside have cooled down before handling.
9. This device is not intended for use by persons (including children) with reduced physical or mental capacity, or without specific experience and knowledge, unless supervised or duly instructed on the use of the appliance by a person responsible for their safety.
10. In the pellet tank there is a grille that prevents coming into contact with the auger. Do not remove it unless instructed to do so by your dealer or customer service.
11. Sharp pieces may be present, therefore be careful when using the appliance.
12. Do not make changes to the appliance.

**STANDARDS:**

In all the appliances we produce, the materials intended to come into contact with food are suitable for food use, in compliance with EC Regulation No.1935/2004.

It conforms to EN 61000-3-2, EN 61000-3-3, EN 60335-1, EN 60335-2-102.

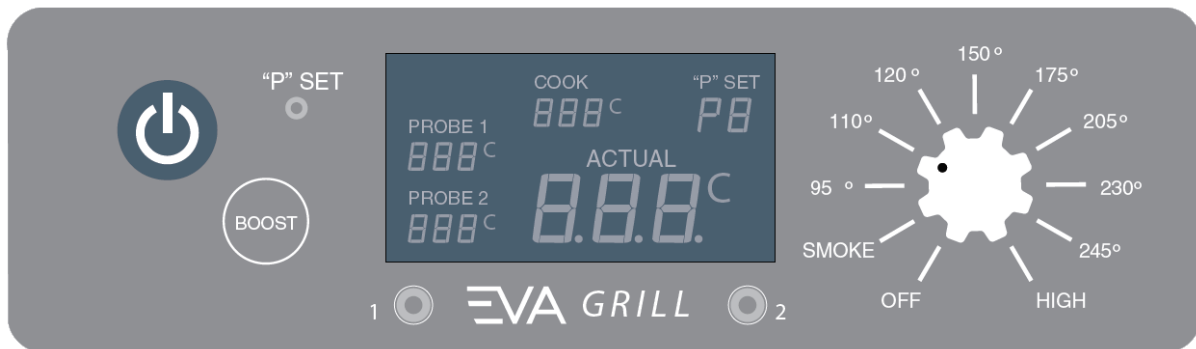
**02. EXPLANATION OF THE DISPLAY AND VARIOUS CONTROLS**

The on/off button allows you to turn the barbecue on or off. It is also backlit blue when the barbecue is connected to the power.



The adjustment ring allows you to select the desired temperature. After connecting the device to the power and pressing the on/off button, rotate until the desired temperature/mode is chosen, in a range from 80° to 260°. This will make the screen turn on, when the indicator turns to off this will turn off.



The "P SET" allows you to select one of the 8 different programmes 'P' when the adjusting ring indicator is in the SMOKE POSITION

**HOW THE "P" FUNCTION WORKS**

Pressing the " P SET " button the P indicator on the display will start flashing and change by increasing the value on the display of a unit. The default set at each ignition is P4. The sets are 8 and go from P0 to P7, once the latter is reached, if the button is pressed again it will restart from P0. Do not apply too much force by pressing the button to avoid damaging it.

If you change the "P SET" while the barbecue is set in SMOKE mode, the auger will continue to load the pellet for 4 minutes. At the end of this time, the auger will start to turn following the "P SET" selected.

AUGER OPERATION (s)

SET "P"	POWER ON	OFF
P0	18	55
P1	18	70
P2	18	85
P3	18	100
P4	18	115
P5	18	130
P6	18	140
P7	18	150



The LCD will display the desired cooking temperature, actual cooking temperature and meat probe temperatures (if connected).



When held down, the BOOST button will trigger an extra pellet feed in the brazier. This can be used for quick heat recovery or while smoking, to increase the intensity of the smoked flavour. It is also used to fill the auger channel in case the pellet is replaced or the tank is filled after it has been completely emptied.



The SMOKE setting on the temperature control knob is the unit start mode and works at the lowest temperature. It also allows you to smoke the food inside the room, allowing the aromas of the pellet to flavour especially the meats.



The plug-in connection ports on the front of the control board handle meat probes. When a probe is connected, the temperature is displayed on the LCD screen.

## BARBECUE PROBES

Our barbecue has two different types of probes:

### • INNER CHAMBER PROBE

Positioned on the left side of the cooking chamber, protected by a steel heat shield. It is shaped like a tapered cylinder. Measure the temperature inside the cooking chamber which will then be shown on the display. This also allows the control board to adjust the amount of pellets to adjust to the set temperature. The detected temperature is influenced by various factors such as the external temperature, the amount of food inside the chamber and the type of pellet used.

### • MEAT PROBE

It is an external probe that is connected directly to one of the two plug-in ports on the control board. It allows you to directly measure the internal temperature of the meat. After connecting it and inserting the cylindrical steel part into the thickest part of the meat it will show the internal temperature of the piece directly on the LCD screen. Always make sure that the probe and cable are not in contact with flame or excessive heat. To avoid this, pull the wire through the hole to the left of the chamber. Store it aside when it is not used to make sure it does not get damaged.

## 03. HOW TO USE THE BARBECUE CORRECTLY

### STARTING THE BARBECUE FOR THE FIRST TIME

Below are the various operations to be performed when you turn on the barbecue for the first time.

#### LOADING THE AUGER TUBE (This operation must also be performed whenever the pellet in the auger tube runs out)

1. Open the pellet cover and make sure that there is nothing that can block the rotation of the auger
2. Remove the various steel grills and hobs from the inside of the barbecue
3. Connect the barbecue to the power supply, press the ON/OFF button and use the selector to set the SMOKE MODE
4. Make sure you feel the auger turn and put your hand over the brazier in order to feel if the fan is injecting combustion air. Be careful not to get too close as you may get burned.
5. After about a minute, make sure you smell the candle lit and the combustion air warm up.
6. Once this is done, turn off the device and fill the tank with the barbecue pellet
7. Now turn the device back on and put it back into SMOKE mode. Press the BOOST button until you see the pellet begin to fall into the brazier, then release the button.
8. Switch off the appliance again
9. Reposition the steel grills and tops inside the barbecue

In order to avoid unpleasant smells and flavours that would ruin the meat during the first use, it is necessary to perform a first "vacuum cooking" of the barbecue. First of all, rinse the grills. Turn on the barbecue and let it go at any temperature above 175° C, keeping the lid closed and letting it go for at least 40 minutes.

#### AUTO-START

1. Connect the barbecue to the power. Check that there are no foreign bodies in the brazier and tank. Fill the tank with the barbecue pellet.
2. Select SMOKE mode and press the power button. Make sure that all the components work by checking if the spark plug heats up, there is movement of the auger and the air fan. When switching on, keep the barbecue lid open.
3. The barbecue will start to produce a white and somewhat dense smoke, when it starts to thin the ignition will be finished.

#### SWITCHING OFF THE DEVICE

After checking that the chamber cover is closed, press the power off button and turn the ring nut to the OFF position.

#### COMPARTMENT FOR COOKING GREASE TRAY

The barbecue has a convenient compartment (image on the right) that allows you to place a tray to contain cooking fats. Maximum tray dimensions: L 31 x H 13 x D 14 cm

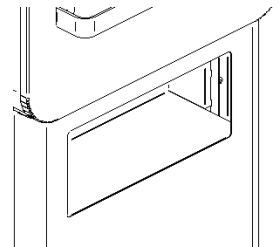

## 04. BARBECUE MAINTENANCE

### 1. TANK CLEANING

- The tank has a convenient pellet discharge that allows it to be emptied very easily. To do this, unscrew the nut below and remove the drain plug, making sure that a container is available under the tank to pour the pellet. This operation must be performed if you want to change the type of pellet to be used or preserve the pellet if the barbecue is stored. We recommend using a brush or vacuum cleaner to remove any remaining debris. Make sure that the appliance is not connected to the power supply before carrying out this operation
- After this operation, make sure to empty the auger by running the appliance with the tank empty until the channel is emptied
- For optimal cleaning, unscrew the side panel and remove any grease and dust on the electronics, especially pay attention to the air fan

### 2. PROBES

- Make sure that, both during use and when stored, there are no knots or tight tangles on the probe cable
- Do not wash the probes in the dishwasher as they may be damaged

### 3. INNER SURFACES

- Vacuum and clean the brazier after each use to prevent the accumulation of ash and debris
- Clean the grilles after each use to prevent grease build-up that could lead to fires. For easier and more accurate cleaning it is preferable to do so when the grills are still slightly hot
- Do not put aluminium foil inside the chamber

#### 4. EXTERNAL SURFACES

- For cleaning external surfaces simply use hot water and soap, avoid any other detergent or abrasive objects. Make sure the barbecue is cold before cleaning it. The painted parts are not covered by warranty, but can be easily retouched with a high temperature barbecue paint
- Make sure to always keep the barbecue protected from the elements both during use and when stored for non-use. For long downtimes keep it in a place protected from moisture

#### COMPONENT CLEANING

- **INTERNAL COMPONENTS OF THE CHAMBER (GRILLS, PLATES, BRAZIER):** Clean after each use to prevent the accumulation of dust and debris that could cause unexpected fires
- **EXTERNAL PART (AESTHETIC):** Clean it if there are dust or dirt accumulations that could affect the paint. Remember to use a cloth with hot water and soap. Do not use other detergents or abrasive materials
- **TANK AND SCREW CONVEYOR:** Clean each time you finish or change the pellet bag, or if you have to store the appliance for long periods
- **ELECTRICAL COMPONENTS:** Clean once a year to remove dust residues, paying particular attention to the air motor blades

#### 05. TROUBLESHOOTING

PROBLEM	CAUSE	SOLUTION
DISPLAY SWITCHED OFF	POWER OUTAGE	CHECK PLUG AND POWER SUPPLY.
	FAULTY ELECTRICAL CABLE	CALL TECHNICAL SUPPORT.
	INTERRUPTED FUSE IN CONTROL BOARD	CALL TECHNICAL SUPPORT.
	FAULTY CONTROL BOARD	CALL TECHNICAL SUPPORT.
	FAULTY DISPLAY	CALL TECHNICAL SUPPORT.
FAILURE TO TURN ON THE PELLET	AUGER NOT LOADED	IT MAY BE NECESSARY TO REPEAT THE FIRST LOAD PHASE A FEW TIMES TO FACILITATE THE APPLIANCE INITIAL START-UP AS THE AUGER TUBE IS COMPLETELY EMPTY AND IT MAY TAKE A SPECIFIC PERIOD OF TIME TO FILL.
	AUGER OBSTRUCTED	REMOVE THE GRILLS, PRESS THE ON BUTTON AND SET THE SMOKE MODE. THEN CHECK THE CORRECT OPERATION OF THE SCREW CONVEYOR VISUALLY. IF IT DOESN 'T WORK, CONTACT SUPPORT
	IGNITION SPARK PLUG PROBLEMS	REMOVE THE GRILLS, PRESS THE ON BUTTON AND SET THE SMOKE MODE. THEN CHECK THE CORRECT FUNCTIONING OF THE SPARK PLUG BY CHECKING IF THIS EMITS HEAT. IF IT DOESN 'T WORK, CONTACT SUPPORT
ERROR "Err"	TEMPERATURE SENSOR ERROR	CHECK THAT THE PROBE IS CONNECTED CORRECTLY AND THAT IT IS WORKING
ERROR "ErL"	INSUFFICIENT PELLET	LOAD SUFFICIENT PELLETS
	SPARK PLUG PROBLEM	CHECK SPARK PLUG OPERATION AND IF NECESSARY CALL FOR ASSISTANCE
ERROR "ErH"	TEMPERATURE ERROR TOO HIGH	LOWER THE TEMPERATURE
		CHECK THAT THE PROBE IS CONNECTED CORRECTLY AND THAT IT IS WORKING
THERE ARE HIGH FLAMES	ACCUMULATION OF GREASE RESIDUES ON COOKING RACKS	CLEAN THE GRILLES AS INDICATED IN THE MANUAL
	HIGH COOKING TEMPERATURE	LOWERING THE COOKING TEMPERATURE
SMOKE MODE TEMPERATURE ELEVATED	INCORRECT "P SET"	PRESS "P SET" BUTTON TO INCREASE P FUNCTION
TEMPERATURE ON THE DIPLAY FLASHES	TEMPERATURE BELOW 65°C/150 F	CHECK THAT THE AUGER AND IGNITION SPARK PLUG ARE WORKING CORRECTLY AS EXPLAINED ABOVE. CHECK THAT THERE IS SUFFICIENT PELLET AND THAT THE VENTILATION ROUTES ARE FREE
EXCESSIVE SMOKE FORMATION	OBSTRUCTED BRAZIER	CLEAN THE BRAZIER AND RECHARGE THE AUGER TUBE AS EXPLAINED ABOVE
	NO AIR INFLOW	CHECK THE CORRECT OPERATION OF THE FAN AND THE AIR PASSAGE. IF NECESSARY, CLEAN AS EXPLAINED ABOVE
	WRONG TYPE OF PELLET	REPLACE THE PELLET IN THE TANK AND REFILL THE SCREW. TURNING THE BARBECUE BACK ON
	GREASE RESIDUES	CLEAN THE GRILLES AS INDICATED IN THE MANUAL

#### 06. BARBECUE DEPALLETTISING AND ASSEMBLY

1. Remove the M10 screw with the relative washer from the previous fixing bracket, keep the screw and the washer just removed
2. Remove the self-drilling screws and washers holding the barbecue left leg fixing brackets (19)
3. Remove the M6 nuts that hold the right leg of the barbecue (34) fixed to the bracket
4. Fit the 2 large barbecue wheels (21) using the M10 screws with the relevant washers previously removed
5. Secure the 2 swivel wheels of the barbecue using 4 M6 screws for each one

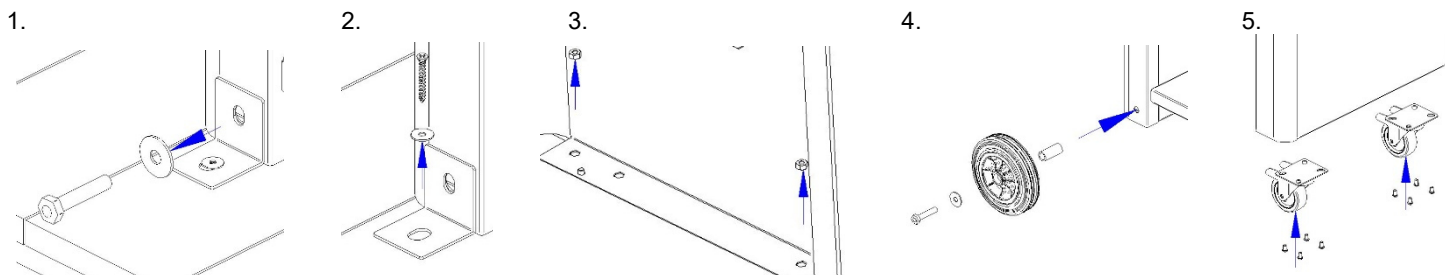

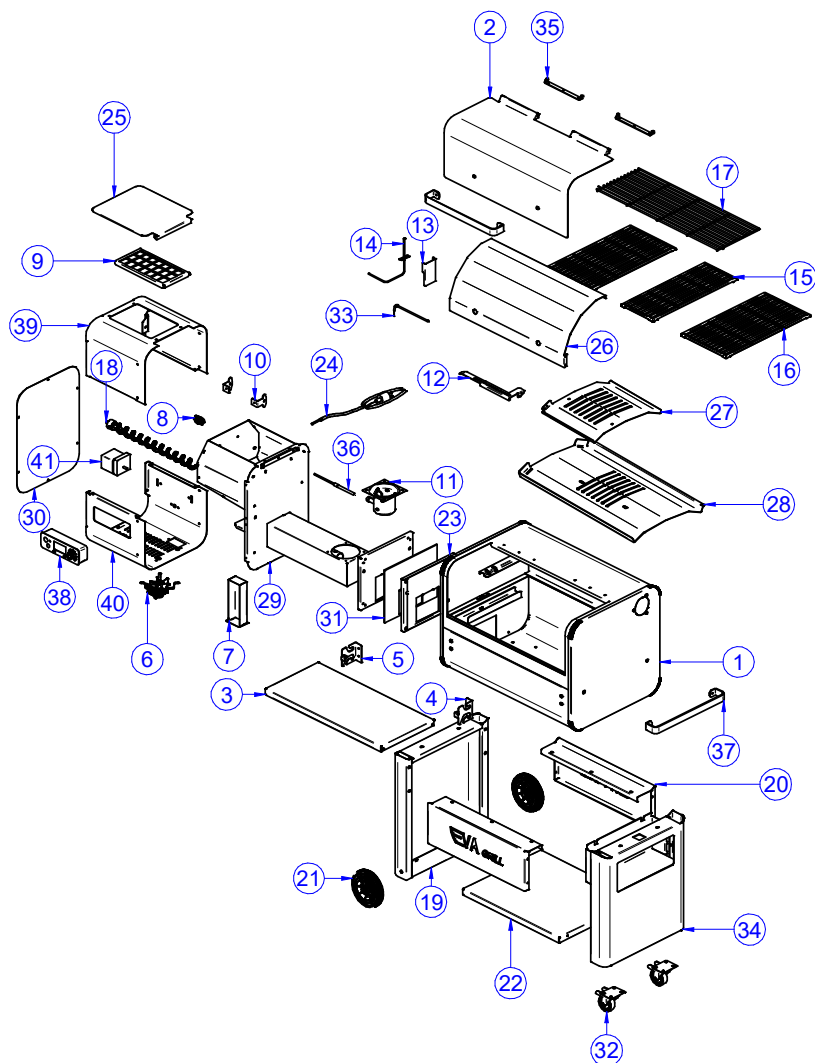

Item Number	Document number	Title	Quantity
1	901588300	BARBECUE BODY	1
2	901588400	BARBECUE LID	1
3	9010810600	REMOVABLE TRAY	1
4	9010811700	RIGHT SHELF SUPPORT BRACKET	1
5	9010810700	LEFT SHELF SUPPORT BRACKET	1
6	9510050000	AIR MOTOR	1
7	901588700	BARBECUE PELLET CAP	1
8	951008100	CABLE TRAY	1
9	9010811100	TANK PROTECTION GRID	1
10	9010810900	BBQ CABLE REELS	2
11	9510050300	BARBECUE BRAZIER	1
12	9010811200	FLAME SELECTOR MOVEMENT BRACKET	1
13	9010811400	BARBECUE TEMPERATURE PROBE PROTECTION	1
14	9510049600	GRILL TEMPERATURE PROBE	1
15	9510050500	SMALL ENAMELLED GRILL	1
16	9510050400	LARGE GLAZED BBQ GRILL	2
17	9510050600	ENAMELLED STEEL WIRE GRILL	1
18	9510050200	BARBECUE AUGER	1
19	9010810500	LEFT BARBECUE LEG	1
20	9010810400	CENTRAL BARBECUE CASING	2
21	9510049000	LARGE BARBECUE WHEEL	2
22	9010810300	BARBECUE CENTRAL PLATE	1
23	9010811000	BARBECUE TANK SPACER	2
24	9510049900	POWER CORD	1
25	9010810200	BARBECUE PELLET LID	1
26	9010811300	BARBECUE INTERNAL DEFLECTOR	1
27	9010811600	BARBECUE DIRECT FLAME SELECTION PLATE	1
28	9010811500	BARBECUE INTERNAL SHELF	1
29	901588500	BARBECUE SCREW BOX	1
30	9010810000	ELECTRONIC BARBECUE LID	1
31	9510050800	BARBECUE TANK INSULATION	1
32	9510050700	BARBECUE SWIVEL WHEELS	2
33	9510049800	GRILL MEAT PROBE	1
34	901588600	RIGHT BARBECUE LEG	1
35	9010808300	BARBECUE HINGE	2
36	9510049700	GRILL IGNITION SPARK PLUG	1
37	9010807900	BARBECUE HANDLE	2
38	9510049500	BARBECUE CONTROLLER	1
39	9010810100	BARBECUE TANK LOCK COVER	1
40	9010810800	BOTTOM OF TANK BLOCK	1
41	9510050100	AUGER MOTOR	1

**Warranty**

Eva Stampaggi S.r.l. guarantees that the barbecue is built using high quality and non-polluting materials.

Eva Stampaggi S.r.l. guarantees that the appliance is free from defects that make it unsuitable for its intended use or significantly reduce its value. The rules of the Italian Civil Code or applicable national law governing the guarantee in the sales contract, or applicable national law ex D. Int.

Any non-conformity can be claimed under the guarantees and procedures provided for in Legislative Decree 206/2005, provided that the Buyer was aware of the defect, or could not ignore it with ordinary diligence, or if the lack of conformity derives from instructions or materials provided by the same.

The warranty excludes malfunctions, defects and/or faults and consequent damage, resulting from things and/or people, attributable to abnormal and/or improper use of the product and/or non-compliant with safety regulations and/or the "Pellet Barbecue Instruction Manual".

The aforementioned warranty is also excluded for defects in conformity, malfunction, defects and/or faults and the consequent damage, caused to property and/or persons, resulting from the use of the barbecue in a manner that does not comply with safety directives.

The warranty for malfunction, defects and/or defects and/or faults does not work and Eva Stampaggi S.r.l. assumes no responsibility for damage caused to property or persons resulting from: violation and/or non-compliance with the provisions of this Instruction Manual; tampering and/or alteration of the appliance and its electrical board; non-compliance with warning lights and alarms; failure to clean and maintain the barbecue; failure to comply with the installation requirements; failure to comply with the procedures for reporting conformity defects provided for in Legislative Decree 206/2005; from the use of unsuitable or poor-quality fuel; from modifications and/or repairs carried out without prior notification and corresponding authorisation by Eva Stampaggi S.r.l.; from the use of non-original and/or non-specific spare parts for the barbecue.

The above list must be considered non-exhaustive and therefore the cases not expressly indicated but which, by virtue of analogical interpretation, can be equated with the cases listed must also be considered included among the cases of exclusion of the guarantee.

Eva Stampaggi S.r.l. assumes no responsibility for: damage to chrome finished and/or anodised metal parts and/or painted or otherwise with treated surfaces, whether due to rubbing or impact with other metals; damage to chrome finished and/or anodised metal parts and/or painted or with treated surfaces, whether due to improper maintenance and/or cleaning with products or chemical agents (said parts must be cleaned using only water); damage to mechanical components and mechanical parts due to improper use or installation by non-specialist personnel or for installation not in compliance with the instructions contained in the packaging; damage to electrical or electronic components and parts due to improper use or for installation not in compliance with the instructions contained in the packaging.

Ignition resistors are material subject to wear and tear, the duration of which depends on the use of the appliance; the relative warranty is therefore limited to the first 6 months of use of the product.

**Attention: after purchase, keep the warranty certificate together with the original packaging of the product and the receipt issued by the seller. The date of the sales tax document will determine the actual duration of the warranty.**

**The warranty provided shall be subject to the following terms and conditions:**

The **after-sales** procedure is managed by our staff, who may be contacted on **+39 0438 35469** or by sending an e-mail to [assistenza@evacolor.it](mailto:assistenza@evacolor.it)

Our qualified staff will provide you with information concerning technical, installation or maintenance problems.

If the problem cannot be resolved over the phone, our staff will forward the issue on to the user's **Technical Assistance Centre**, who will guarantee service within five working days

Any parts replaced during the warranty period shall be covered for the remaining period of the purchased product warranty.

The manufacturer shall not pay the customer any indemnities for the inconvenience of not being able to use the product during the period required for repairing.

Should it be necessary to replace the product, the manufacturer will deliver it to the dealer who will then deliver it to the end user following the same procedure as for the product purchase.

This guarantee is valid within Italy; in the event of sale or installation carried out elsewhere, the guarantee must be recognised by the distributor in that territory.

The warranty is carried out with the repair or replacement of defective parts, or defective parts or the entire product, at the discretion of the company.

**IMPORTANT:**

**EVA STAMPAGGI RECOMMENDS CONTACTING ITS RETAILERS AND AUTHORISED ASSISTANCE CENTRES.**

**EVA STAMPAGGI IS NOT RESPONSIBLE FOR ONLINE SALES AND FOR RELATED OFFERS AS IT DOES NOT OFFER DIRECT SALES TO THE PUBLIC.**

**FOR ANY TECHNICAL ISSUES DURING THE PERIOD OF LEGAL WARRANTY, THE PROCEDURE REQUIRES CONTACTING OF THE RETAILER OR DIRECTLY OF OUR AFTER SALES.**

**WARNINGS for correct disposal of waste electrical and electronic equipment (WEEE) in accordance with EC Directive 2002/96/EC and subsequent amendment 2003/108/CE.**

Application of this symbol on the product determines that it is NOT waste that can be considered generic but should be demolished and disposed of in compliance with the regulations in force in the country of use, making sure that the special collection centres are legally compliant both in relation to safety and in terms of respecting and protecting the environment. Responsibility for such disposal is borne by the owner and to avoid incurring penalties or negative consequences for the environment and health, we advise directly contacting the municipal authorities, the local authority for waste disposal or the retailer, to learn more about the places and ways of collection.

The correct disposal of waste is important not only for the environment and for the health of citizens but also because this operation involves the recovery of materials with consequent important savings of energy and resources.

Eva Stampaggi S.r.l.  
Via Cal Longa Z.I.  
I - 31028 Vazzola (Treviso - Italy)  
Tel. +39.0438.740433 rollover lines  
Fax +39.0438.740821  
Email: [info@evacolor.it](mailto:info@evacolor.it)

**Dealer Stamp and Signature**



Eva Stampaggi S.r.l.  
Via Cal Longa Z.I.  
31028 Vazzola (TV) ITALY  
Tel: +39 0438 740433  
Fax: +39 0438 740821

I dati e le caratteristiche indicate non impegnano Eva Stampaggi S.r.l., che si riserva il diritto di apportare le modifiche ritenute opportune senza obbligo di preavviso o di sostituzione.  
All rights reserved. Vietata riproduzione totale o parziale senza espressa autorizzazione di Eva Stampaggi S.r.l.

The data and features indicated are in no way binding to Eva Stampaggi S.r.l. The company reserves the right to make any necessary changes without prior notice or replacement obligation.  
All rights reserved. Total or partial reproduction is prohibited without the express authorisation of Eva Stampaggi S.r.l.

Les données et caractéristiques indiquées n'engagent pas Eva Stampaggi S.r.l., qui se réserve le droit d'apporter les modifications jugées opportunes sans obligation de préavis ou de remplacement.  
Tous droits réservés. La reproduction totale ou partielle sans autorisation expresse de Eva Stampaggi S.r.l. est interdite.

Die angegebenen Daten und Eigenschaften binden das Unternehmen Eva Stampaggi S.r.l. nicht, das sich das Recht vorbehält, ohne zu Vorankündigungen oder Ersetzungen verpflichtet zu sein, für opportun gehaltene Änderungen vorzunehmen.  
Alle Rechte vorbehalten. Der vollständige oder teilweise Nachdruck ist ohne die ausdrückliche Genehmigung der Eva Stampaggi GmbH nicht gestattet.

Los datos y las características que se indican no son vinculantes para Eva Stampaggi S.r.l. que se reserva el derecho de efectuar las modificaciones que juzgue oportunas sin previo aviso o sustituciones.  
Todos los derechos están reservados. Prohibida la reproducción total o parcial sin la autorización expresa de Eva Stampaggi S.r.l.

Os dados e as características indicadas não comprometem a Eva Stampaggi S.r.l., que se reserva o direito de efetuar as modificações consideradas oportunas sem obrigação de aviso prévio ou de substituição.  
Todos os direitos reservados. É proibida a reprodução total ou parcial sem a autorização expressa da Eva Stampaggi S.r.l.