

EN

BURNIT
by **SUNSYSTEM**

PELLET BURNING BOILER
Pell Easy series

TECHNICAL PASSPORT
INSTALLATION and OPERATION MANUAL FOR
AUTHORIZED INSTALLER / SERVICE SHOP



Version i0.0.2



TABLE OF CONTENTS

1.	EXPLANATION OF SYMBOLS AND SAFETY INSTRUCTIONS	4
1.1.	Explanation of symbols	4
1.2.	Requirements to boiler installation room	4
1.2.1.	Instructions to boiler installer	4
1.2.2.	Instructions to installation user	5
1.2.3.	Minimum clearances for installation and flammability of construction materials-6	
2.	PRODUCT DESCRIPTION	7
2.1.	Design structure of boiler Pell	7
2.2.	Safety devices of pellet boiler and burner	7
3.	FUELS	8
4.	TRANSPORTATION OF THE BOILER	10
5.	DELIVERY OF THE BOILER	11
6.	INSTALLATION OF THE HEATING BOILER	11
7.	SETUP OF THE HEATING BOILER	11
7.1.	Connecting the boiler to a chimney	11
7.2.	Connecting the boiler to the mains power supply	13
7.3.	Connecting the boiler to the heating installation	16
7.4.	Air Bleeding.....	16
7.5.	Connecting diagrams.....	18
8.	FILLING THE HEATING INSTALLATIO	22
9.	OPERATION OF BOILER	21
9.1.	Operation of pellet boiler Pell Easy	21
9.2.	Important recommendations for long-lasting and correct operation of the boiler ...	22
9.3.	Requirements for the cleaning and maintenance of Pell Easy pellet boiler	22
10.	MICROPROCESSOR CONTROLLER	27
11.	CONNECTING WI-FI MODULE TO THE PELLETT BOILER	36
12.	WARRANTY TERMS	38
13.	TECHNICAL FEATURES	43
13.1.	Technical features of Pell Easy pellet boiler	43
13.2.	Technical parameters of Pell Easy pellet boiler.....	44
14.	RECYCLING	47

1. EXPLANATION OF SYMBOLS AND SAFETY INSTRUCTIONS

1.1. Explanation of symbols

CAUTION! - Important recommendation or warning concerning safety conditions during installation and operation of boiler.



DANGER! - fault or improper use may cause injury or be hazardous to life of humans or animals.



FIRE HAZARD!- fault or improper installation and operation may cause fire.



INFORMATION- Important information on the proper operation of the product.



1.2. Requirements to boiler installation room

This manual contains important information for the safe and correct installation, start-up and trouble-free operation and maintenance of the boiler. The Pellet boiler can be used for heating rooms only in the manner described in this manual.

The application and any other was the area of operation is not recommended by the manufacturer and is not responsible for the occurrence of defects or failures. Note the boiler type data on the factory rating label and the technical data provided in chapter 14 in order to ensure proper operation of the product.

1.2.1. Instructions to boiler installer

During installation and operation, the country-specific requirements and regulations must be observed:

- Local construction regulations on installation, air supply and exhaust gas extraction as well as chimney connection.

- Regulations and norms concerning the fitting of the heating installation with safety devices.
- Required installation of a smoke detector in the boiler room.

	Use only original BURNiT parts
--	--------------------------------

	WARNING! Installation and setup of the boiler should be done by an authorized specialist / service shop and must follow the safety instructions and rules of operation.
--	--

	DANGER of intoxication, suffocation. Inadequate inflow of fresh air to the boiler room may result in dangerous leak of exhaust gases during boiler operation. - Make sure the air inlets and exhaust gas outlets are not clogged or closed. - If faults are not remedied immediately, the boiler must not be operated. - The user must be provided with written instructions on the fault and the hazard it entails.
--	--

	DANGER of fire when burning flammable materials or liquids. - Flammable materials/liquids must not be left in close proximity of the burner and heating boiler. - Instruct system user of the allowed minimum clearances from surrounding objects.
--	---

	It is mandatory to assure a backup power generator of corresponding rated power! (see table 1)
--	--

	Customer must undergo boiler operation/maintenance training by authorized installer/service shop
--	--

Table 1.
Electricity consumption of the boiler

Maximum electrical input	360 W
Electrical input at nominal heat output	70 W
Electrical input at minimum heat output	45 W

1.2.2. Instructions to installation user

	<p>DANGER of intoxication or explosion <i>Toxic gases may be discharged when burning waste, plastics, liquids.</i></p> <ul style="list-style-type: none"> - Use only the fuels indicated in this manual. - In case of danger of explosion, ignition or discharge of exhaust gases in the room, stop the pellet burner from operation.
--	--

	<p>It is mandatory to assure a backup power generator of corresponding rated power! (see table 1)</p>
--	--

	<p>Customer must undergo boiler operation/maintenance training by authorized installer/service shop.</p>
---	---

	<p>CAUTION! Danger of injury / damage of system due to incompetent operation.</p> <ul style="list-style-type: none"> - The boiler must be serviced only by persons familiar with the operation manual. - As user, you are only allowed to start the boiler up, adjust the temperature of the boiler, shut the boiler down and clean it. - Unattended children must not be allowed access to premises with running boiler inside.
--	--

Safety rules for user operation:

- Operate the boiler on recommended fuel only, and to that end you must regularly inspect the boiler room.
- Do not use flammable liquids for ignition or increase of burner output.
- Clean the boiler surface using non-flammable agents only.
- Do not place flammable objects onto the burner housing and heating boiler cabinet or in their proximity. (see diagram 1 for the minimum clearances)
- Do not store flammable materials in the boiler room.
- It is mandatory to strictly observe instructions for connecting the burner to power network as well as to all peripherals.
- Structural changes of the boiler by user can cause damage to equipment or injury.
- Do not allow contact transmission of electrical wire or touch any part of the boiler, where the surface temperature can exceed 70 °C.
- This manual should be kept throughout

	<p>CAUTION! Hot surface! Risk of burns if you touch the running system. Burner housing, body and flange are hot surfaces during burner operation.</p> <p><i>It is strictly prohibited to open boiler inspection doors with the burner running.</i></p> <p><i>The hopper hatch cover is not allowed to remain open for longer periods of time.</i></p> <p><i>Also, exercise caution when touching the observation port for monitoring the burning process. It may be hot.</i></p>
---	--

1.2.3. Minimum clearances for installation and flammability of construction materials

The applicable minimum clearances in your country may differ from the ones specified below. Please, consult your installer.

The minimum distance from the burner, heating boiler or exhaust gas pipe to objects or walls must be at least 200 mm.

Class A – non-flammable	Stone, bricks, ceramic tiles, baked clay, solutions, plaster free of organic additives.
Class B – hardly flammable	Gypsum board panels, basalt fiber needled felt, fiberglass board, AKUMIN, Izomin, Rajolit, Lignos, Velox, Heraklit.
Class C1/C2 Medium flammable	Wood beech, oak. Wood softwood, layered wood
Class C3 – easy flammable	Asphalt, cardboard, cellulose, tar, fiberboard, cork, polyurethane, polyethylene.

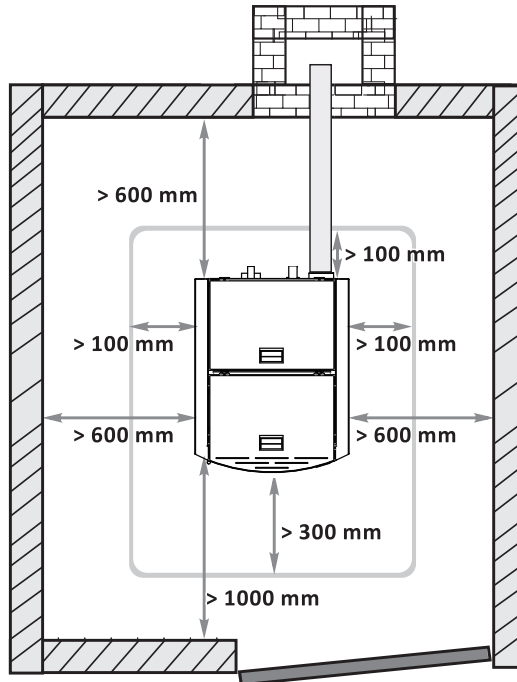

Diagram1. Recommended clearances between boiler and walls.

For general safety considerations, we recommend that the boiler be placed on a foundation made of class A material, see table 2.

2. PRODUCT DESCRIPTION

Ecological and highly-efficient pellet boiler Pell Easy is designed for firing wood-pellets. The mantle fully covers the combustion chamber. Efficiency rate reaching 92%. Approved in accordance with EN 303-5, class 5.

2.1. Design structure of boiler PelleBurn.

Restingular body design is made of high-quality boiler steel sheets with thickness of 4 mm for the combustion chamber and 3 mm for the water mantle.

- **Ecological.** A high-end pellet boiler. The wood-pellets used for fueling the boiler are a renewable fuel with minimum carbon emissions and ultimate burning efficiency.
- **Automated.** All boiler functions are fully automated – no human intervention is needed for the normal operation of the boiler. Owing to an improved algorithm with optional adjustment of a wide variety of parameters, the system may be finely tuned to any particular heating system to achieve optimum efficiency and fuel consumption.

Controller functions:

- 1) fully automated ignition and pellet feed;
- 2) burner self-cleaning function;
- 3) controls the operation of central heating circulation pump;

- 4) controls the operation of DHW (domestic hot water) pump;
- 5) controls by room thermostat;
- 6) flue gas sensor;

- **Efficient.** To keep from losing heat into the ambience, the boiler is insulated on the outside by 50 mm high-temperature wool. With its intelligent state-of-the-art combustion control system the Pell Easy boiler achieves efficiency rate of as much as 92%

2.2. Safety devices of pellet boiler-and-burner

A complex of safety devices provide for the safety of the appliance. Air-feed fan, step –regulated, controls the combustion according to energy needs and is maintained in optimal working order. Independent STB thermostat shut-off the burner and shut off the fuel feeding in the combustion chamber in case of rising boiler temperature.

- **Thermostatic protection (80°C).** The thermostatic protection is fitted on the auger chute. When the surface of the feeder chute reaches 80°C, the control stops the feeding of pellets into the burner and signals for fault.
- **Fuse.** In case of electrical fault in the system of the burner (short circuit, current overload, etc.), the overload is borne by the electrical fuse fitted on the main control panel of the burner (10 A).
- **Power interruption. Innovative controller.** In case of power interruption, all parameter settings are stored in the memory of the controller. Upon the

subsequent restart of the burner, the controller resumes the execution of the program from the point when the power interruption occurred.

3. FUELS



All pellets are biomass manufactured from common low-growing plants and trees. The most common household type pellets are made of sawdust and milled wood chippings which are waste material from wood used in the production of logs, furniture and other products. Wood is the richest raw material which does not have any impact on the production costs of food products or ethyl alcohol (ethanol). The raw material is processed under high-pressure and temperature and is pressed to produce small-size cylindrical pellets. The production process may utilize soft wood material (such as softwood, pine), hardwood (oak) as well as recycled waste wood. Wood pellets are produced in hammer mills or wood pellet plants.

Advantages of wood pellets:

Convenient storage.

Pellet bags can be stored on a small area

in a dry garage, basement, service room or shed.

Easy loading.

In most cases the boiler hopper needs loading only once a week – this depends on the hopper capacity.

Better control of fuel quantity.

The small size of the pellets allows for precise fuel feeding. On the other hand, the supply of air for reaching optimal combustion efficiency is easier to adjust since the fuel quantity in the combustion chamber remains constant and predictable.

Fuel efficiency.

High combustion efficiency is also determined by consistently low moisture content of pellets (consistently under 10% as opposed to 20% to 60% moisture content of the logs). Low moisture content, controlled fuel portions and precise air setting means high combustion efficiency and very low carbon oxides in the flue gases.



When purchasing pellets, ask for conformity declaration and certificate issued by an accredited laboratory and make sure the fuel meets the requirements indicated in the manual. If you purchase large amount of pellets (bulk supply for the entire heating season for example), ask your supplier to provide accurate and true information about the storage conditions.

We recommend to use pellets with size of 6 - 8 mm. Density 600 - 750 kg/m³ heating value 4.7-5.5 kWh/kg. Ash content – less than 1% and moisture content up to 8%.,

EN ISO 17225-2:2014.

The optimal density of the pellets which guarantees their quality is 605-700 kg per cubic meter.

Pellet moisture content must not exceed 10%. Make sure you store your fuel in a dry and well-ventilated place.

The optimal pellet ash content is $\leq 1\%$. This also provides for less frequent cleaning intervals for the burner.

The table below contains the parameters which we recommend that you take into consideration when choosing fuel for your Pell burner.

Table 3. European Certification of Wood Pellets for Heating Purposes

Parameters	Units	ENplus-A1	ENplus-A2	EN-B
Diameter	mm	6 (± 1) 8 (± 1)	6 (± 1) 8 (± 1)	6 (± 1) 8 (± 1)
Length	mm	$15 \leq L \leq 40$ ¹⁾	$15 \leq L \leq 40$ ¹⁾	$15 \leq L \leq 40$ ¹⁾
Bulk density	kg / m ²	≥ 600	≥ 600	≥ 600
Calorific/heating value	MJ / kg	$\geq 16,5-19$	$\geq 16,3-19$	$\geq 16,0-19$
Humidity /moisture	Ma .-%	≤ 10	≤ 10	≤ 10
Dust	Ma .-%	≤ 1 ³⁾	≤ 1 ³⁾	≤ 1 ³⁾
Mechanical durability	Ma .-%	$\geq 97,5$ ⁴⁾	$\geq 97,5$ ⁴⁾	$\geq 96,5$ ⁴⁾
Ash	Ma .-% ²⁾	$\leq 0,7$	$\leq 1,5$	$\leq 3,5$
Melting point of ash	°C	≥ 1200	≥ 1100	-
Chlorine content	Ma .-% ²⁾	$\leq 0,02$	$\leq 0,02$	$\leq 0,03$
Sulfur content	Ma .-% ²⁾	$\leq 0,03$	$\leq 0,03$	$\leq 0,04$
Nitrogen content	Ma .-% ²⁾	$\leq 0,3$	$\leq 0,3$	$\leq 1,0$
Copper content	mg / kg ²⁾	≤ 10	≤ 10	≤ 10
Chromium content	mg / kg ²⁾	≤ 10	≤ 10	≤ 10
Arsenic content	mg / kg ²⁾	$\leq 1,0$	$\leq 1,0$	$\leq 1,0$
Cadmium content	mg / kg ²⁾	$\leq 0,5$	$\leq 0,5$	$\leq 0,5$
Mercury content	mg / kg ²⁾	$\leq 0,1$	$\leq 0,1$	$\leq 0,1$
Lead content	mg / kg ²⁾	≤ 10	≤ 10	≤ 10
Nickel content	mg / kg ²⁾	≤ 10	≤ 10	≤ 10
Zinc content	mg / kg ²⁾	≤ 100	≤ 100	≤ 100

¹⁾ not more than 1% of the pellets may be longer than 40 mm, max. length 45 mm;

²⁾ dry weight;

³⁾ particles <3.15 mm, particulate matter, before handing over the goods;

⁴⁾ measurements with Ligno-Tester limit value $\geq 97,7\%$ by weight.

4. TRANSPORTATION OF THE BOILER

We recommend to transport the heating boiler to the installation site in its packaging placed on the pallet. During transport and installation, depending on the weight, suitable safety devices should be used in accordance with Directive 2006/42/EC.

When transporting items weighing more than 30 kg, the use of pallet jack, fork truck or other hoisting devices is a must.

Product must be in original packaging following the instructions on the label - to be protected from adverse weather

conditions (snow, rain and dust) from the shocks, and other activities likely to cause damage. In case of malfunction of the fan or the motor drive (noise, friction) or failure of high-tech elements such as broken controller-screen, contact your nearest authorized service center for repairs and maintenance.

The boiler is securely fastened with fasteners to a wooden pallet.



Important: When installing the boiler, the wooden pallet onto which the boiler is placed must be removed by unscrewing the bolted connections using flat ring wrench S13.

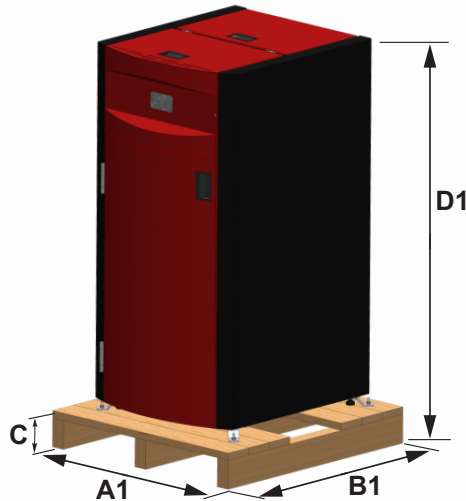

Pell Easy		20	35	35 XL
A1, mm	Котелно тяло, горелка и палет	700	800	1150
B1, mm	Котелно тяло, горелка и палет	800	900	900
C, mm	Котелно тяло, горелка и палет	125	125	125
D1, mm	Котелно тяло, горелка и палет	1370	1380	1380
Тегло, kg	Котелно тяло, горелка и палет	252	347	370

Diagram 2. Indications dimensions

5. DELIVERY OF THE BOILER

- Inspect the integrity of the packaging upon delivery.
- Check whether all components have been delivered to you. Boiler consignment package includes:

1) Pellet boiler Pell Easy.

2) Safety valve 3 bar.

3) Hook

4) Technical passport. Installation and operation manual.

5) Service booklet and Warranty card

If any of the above items are missing, contact your supplier.

6. SETUP OF THE HEATING BOILER



The assembly, installation and set-up of the boiler must be performed by a technician authorized for such operations. Installer must indicate to the user of the installation the minimum clearances from flammable materials and liquids.

Requirements:

- Boiler room must be frost-proof;
- Boiler room must allow for continuous access of air necessary to maintain combustion;
- Boilers must not be placed in inhabitable rooms;
- All boiler rooms must have correctly calculated vent depending on the boiler output. The vent must be protected by means of a net or grate.

The size of the vent is calculated

according to the formula:

A=6,02Q - where:

A – area of the vent in cm²,

Q – boiler output in kW

- Remove the packaging without polluting the environment
- Observe building supervision instructions, in particular the existing Ordinance on combustion devices and storage of combustion materials, on building requirements applicable to installation sites and on ventilation;
- The boiler must be placed on a foundation whose surface area is larger than the base of the heating boiler according to diagram 1;
- The boiler must be placed in a position which allows for the easiest possible cleaning and servicing;
- Installation must be carried out according to installation diagram 1 which shows the boiler housing;
- No objects made of flammable materials or liquids may be placed on/near the boiler;

7. INSTALLATION OF THE HEATING BOILER

7.1. Connecting the boiler to a chimney

Boiler-to-chimney connection must always comply with the existing standards and rules. The chimney must provide sufficient draught for evacuation of the smoke under any conditions.

The proper functioning of the boiler requires adequate sizing of the chimney itself since the draught it produces affects

combustion, boiler's output and life span. The draught created by the chimney is in functional relation to its cross-section, height and the roughness of its interior walls. No other appliance may be connected to the chimney serving the boiler. Chimney diameter must not be smaller than the flue outlet of the boiler. Flue outlet must be connected to the chimney opening. In terms of mechanical properties, the flue outlet must be sturdy and properly sealed (to avoid gas leak) and allow for easy access for cleaning on the inside. The inner section of the flue outlet must not be greater than the effective section of the chimney and must not narrow. Avoid using elbow joints. The chimney cleaning opening has to be in its lowest part. The chimney's wall has to be three plied where the medium layer is from mineral wool. The thickness of the insulation is not less than 30 mm when the chimney is setting up inside the house and the thickness is 50 mm, when the setting up is outside.

Please entrust choosing a chimney and its installation by a qualified professional. The required distance between the boiler and the chimney is 300-600 mm. Draught regulator **(1)** must be installed at least 600 mm from the joint (connection).

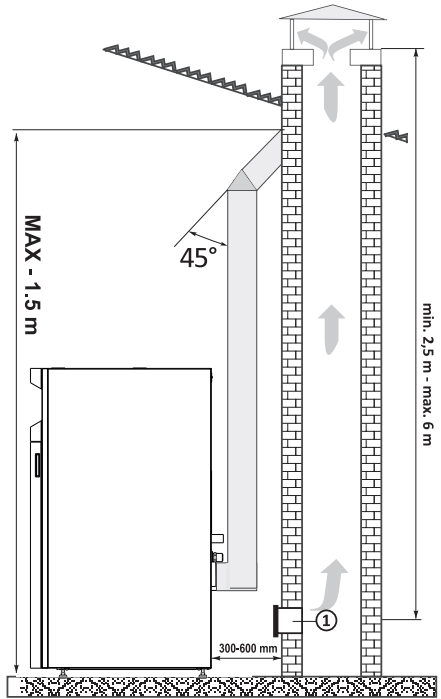



Table 4. Recommended minimum sizes and chimney draft

Model	Chimney diameter, mm	Chimney draft, Pa
20 kW	Ø 100 mm	8 - 10
35 kW	Ø 100 mm	10 - 15





The use of flexible metal tubes of stainless steel or aluminum material is forbidden!

 Data in the tables are for indicative purposes. Draught depends on the diameter, height, uneven sections along the chimney surface and differences in temperature of combustion products and outside air. We recommend that you use chimney fitted with flue terminal. Heating specialist must calculate the precise sizing of the chimney.

7.2. Connecting the boiler to the mains power supply











 Such connection must be performed by a technician / service shop authorized for such operations.

 **Caution! ELECTRIC SHOCK HAZARD!**
- Before opening the unit: switch off the voltage and secure the unit against accidental restart.
- Observe installation instructions.

 It is mandatory to assure a backup power generator of corresponding rated power! (see table 1)

 Improper cable connections may damage the regulator!

 The device may be damaged if struck by a lightning. Make sure it is unplugged during the storms.

	1. Door open switch
	5. External Thermostat
	6. Water temp. sensor
	10. Accumulator temp. sensor
	12. Flue Gas temp.
	14. Igniter
	15. Fan as primary combustion Fan
	19. Pellets Feeder
	21. Safety temp. STB (water)
	22. Safety temp. STB (pellets)
	26. Water Pump

To bring into exploitation the boiler and auger must be connected to the electricity network 220V/50Hz with power cord. Create tight connection with the electrical mains which complies with the local regulations.

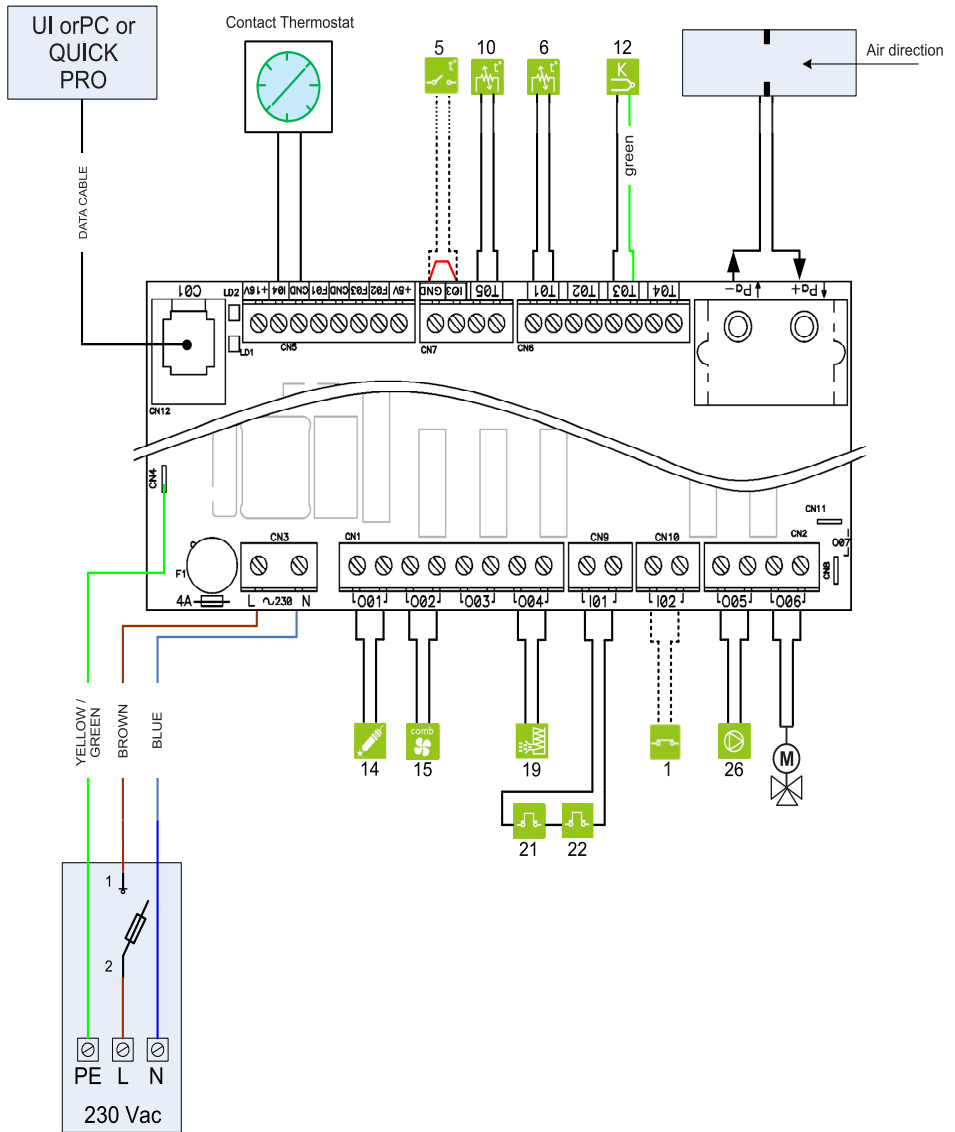

Diagram 3. Wiring diagram of connection of boiler elements to the controller FUMIS - Alpha 65

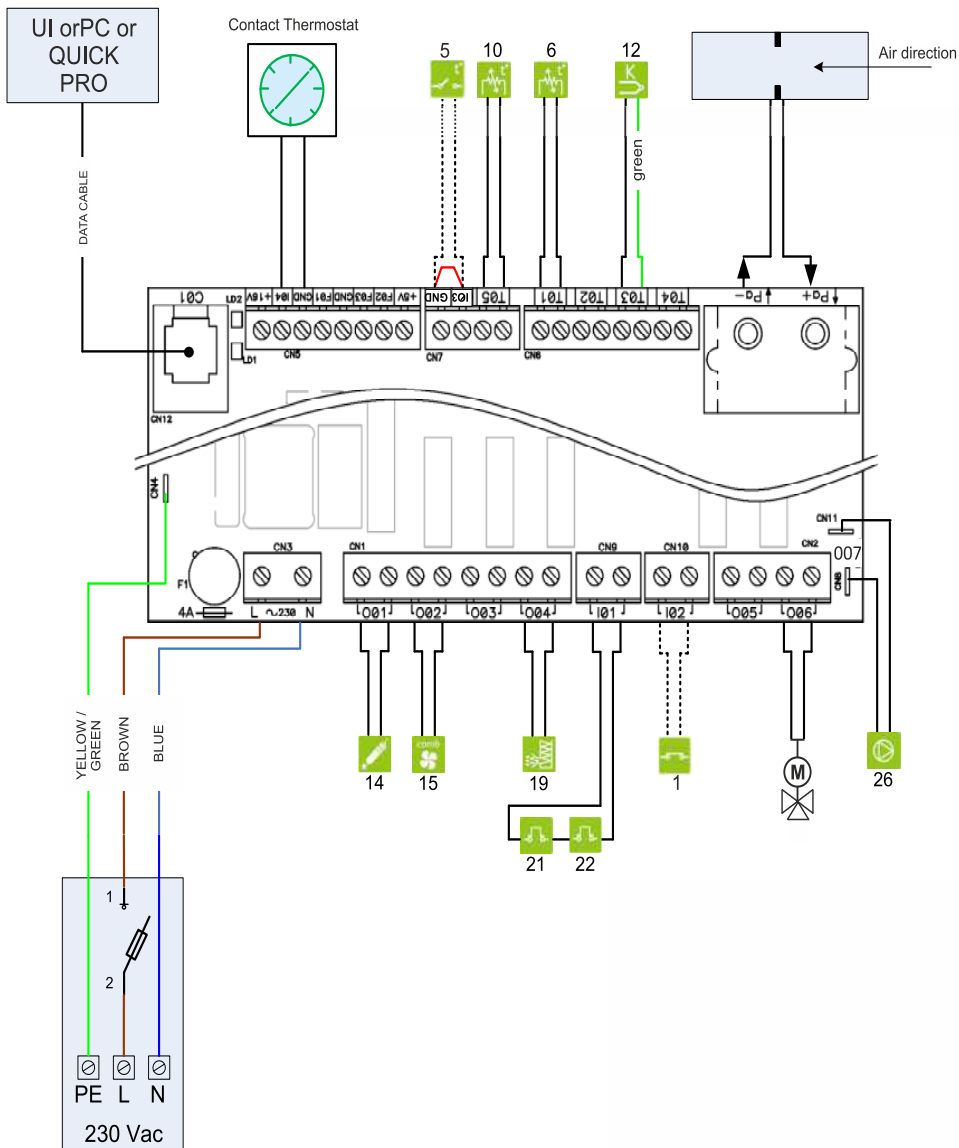



Diagram 4. Wiring diagram of connection of boiler elements to the controller Fumis - Alpha 75

7.3. Connecting the boiler to the heating installation.

 Such connection must be performed by a technician / service shop authorized for such operations.

To bring into exploitation the boiler and auger must be connected to the electricity network 220V/50Hz with power cord. Create tight connection with the electrical mains which complies with the local regulations.

 It is mandatory to install a three-way valve (Laddomat or similar) or a four-way mixing valve which to ensure that the temperature of the heating medium fed into the boiler from the heating installation is at least 45°C.

7.4. Air Bleeding.

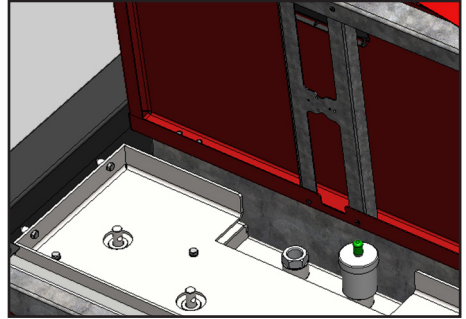



 When filling the system remove the cap of the automatic bleed valve. Once you are sure there is no air in the system reinstall it in place.

Table 5. TROUBLE-SHOOTING TABLE

Installation damage	
Cause	Solution
Due to unsealed connections	Install the connecting piping strain-free to the boiler connections.
Due to freezing	If the heating installation, including the piping network, has not been built frost-proof, we recommend that you fill the heating installation with a liquid which has low freezing point and corrosion protection and antifreeze agent.

Boiler water too hot, heating bodies too cold	
Cause	Solution
<i>The STB safety thermostat has been triggered.</i>	<i>Upon reaching a temperature of 95°C, the thermostatic safety protection device is triggered and the fan is turned off. To resume protection, remove the black cap on the back panel of the boiler and press the button on the STB-thermostat. Contact your installer to determine the cause of protection triggering.</i>
Low boiler temperature. Unable to reach normal temperature mode of 65°-85° C	
Cause	Solution
<i>Inadequate sizing and/or combination of heating appliances</i>	<i>Immediately consult your installer about the problem.</i>
Ejection of unburned pellets into the combustion chamber of the boiler	
Cause	Solution
<i>Poor adjustment of the fuel-to-air ratio from the burner controller</i>	<i>Contact your installer. It is necessary to set the burner properly using gas analyzer</i>
<i>Utilization of low-quality pellets</i>	<i>Use only fuel which meets the requirements specified in the manual. (see section 3. Fuel)</i>
Formation of clinkers and noncombustible inclusions inside burner body	
Cause	Solution
<i>Utilization of low-quality pellets (see section 3. Fuel)</i>	<i>Use only fuel which meets the requirements specified in the manual.</i>
<i>Low performance of the automatic cleaning system</i>	<i>Increase the frequency of inclusions of self-cleaning system</i>
<i>Improper setting of fuel-air mixture</i>	<i>Adjust using gas analyzer</i>
Boiler temperature too high. Controller failure	
Cause	Solution
<i>Grid power fluctuations</i>	<i>It is mandatory to assure a backup power generator of corresponding rated power! (see table 1)</i>
<i>Power failure</i>	
<i>High temperature of exhaust gases. High temperature alarm is turning on</i>	<i>Fume exhaust tubes of boiler water jacket are clogged with soot. Reduced heat transfer. The boiler should be cleaned. Please contact an authorized specialist / service shop to clean the boiler.</i>
<i>High temperature in boiler water jacket and low temperature in the buffer tank.</i>	<i>1. Incorrect ON/OFF temperature settings of pumps. 2. Incorrect sizing of heating system.</i>

7.5. Schemes of connection to the heating system

 Such connections must be performed by a technician / service shop authorized for such operations.

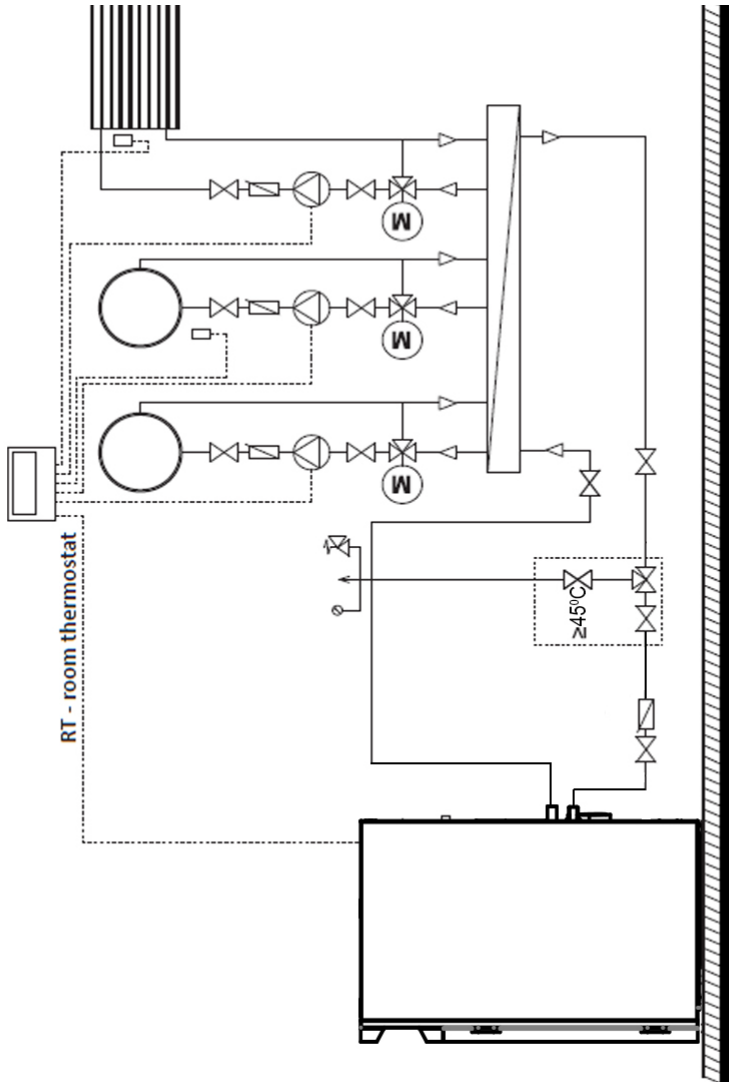

Diagram 45 Connection of boiler Pell Easy to three-way valve

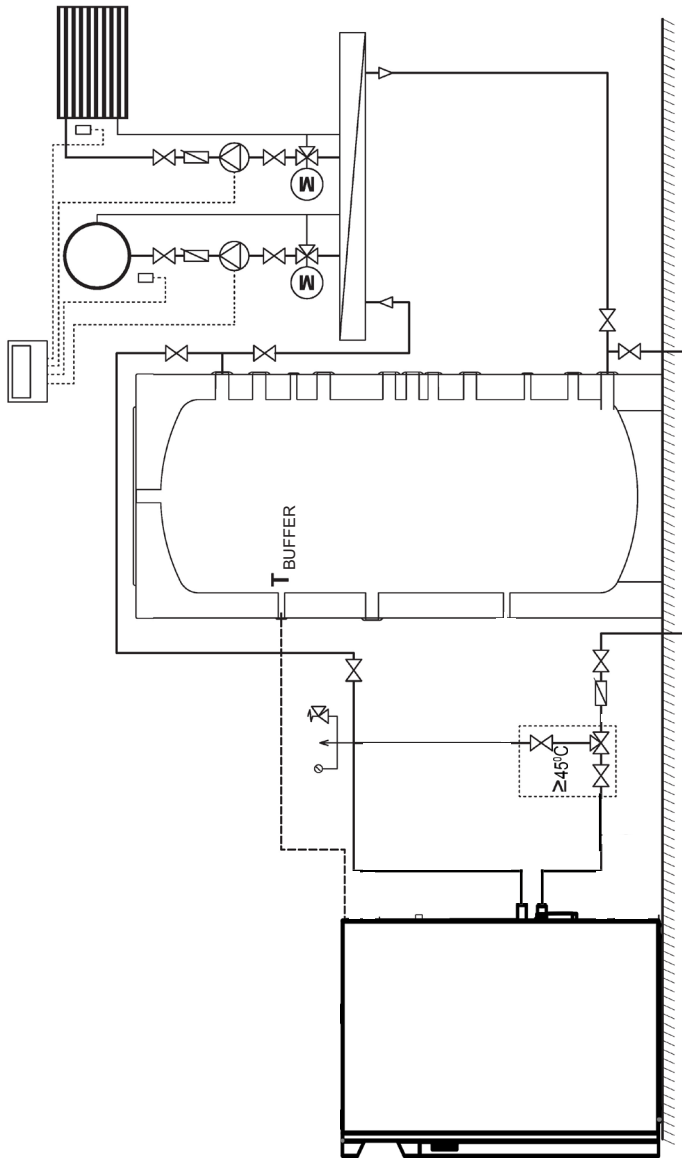

Diagram 6. Connection of boiler Pell Easy to P type buffer tank and three-way valve

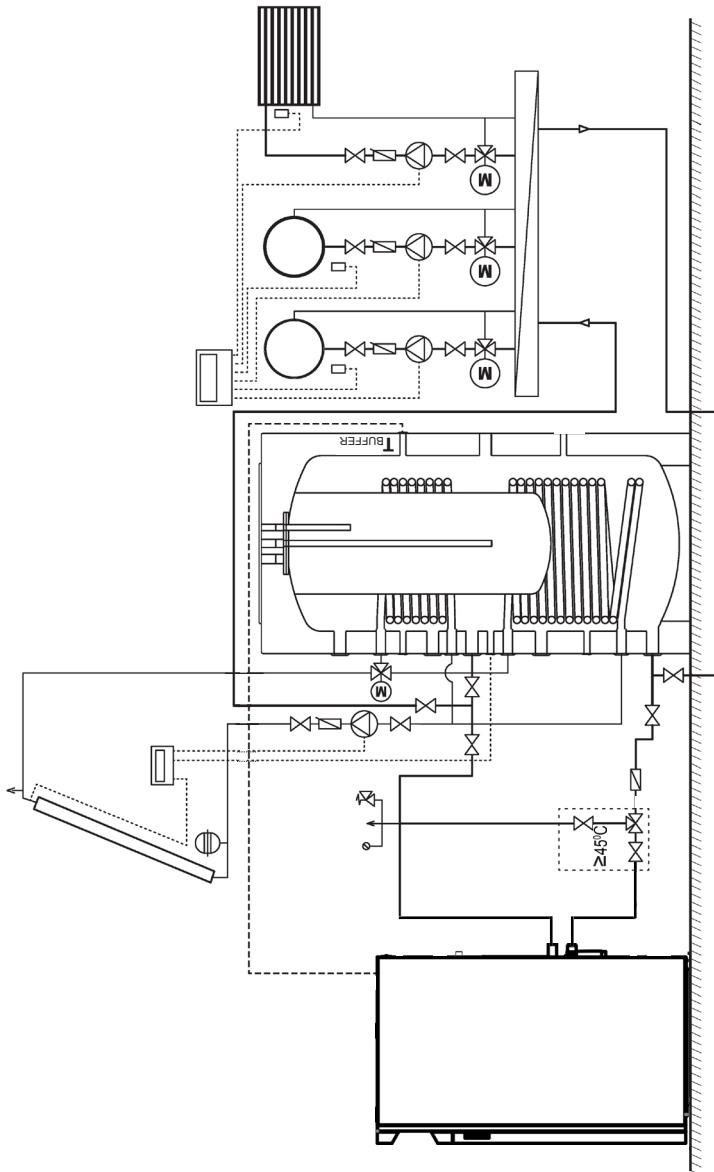

Diagram 7. Connection of boiler Pell Easy to combi tank KSC2, flat plate solar collector PK and three-way valve

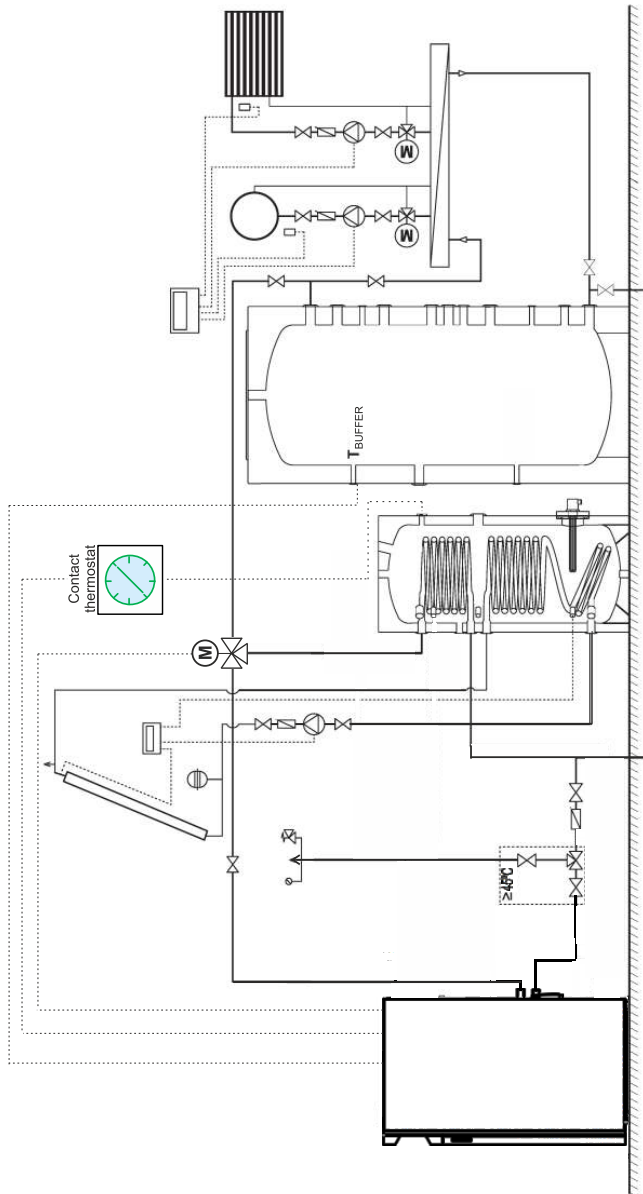

Diagram 8. Connection of boiler Pell Easy to solar tank SON, buffer tank P, flat plate solar collector PK and three-way valve

8. FILLING THE HEATING INSTALLATION

Table 6

Problem	Prevention
Possible installation damage due to strains in the material caused by temperature differences	Fill the heating installation only in cold conditions (inlet temperature must not exceed 40°C).
Danger of installation damage due to accumulation of deposits Condensate formation and tar deposits may shorten boiler's operational life.	<ul style="list-style-type: none"> - Do not operate the heating boiler for a long period of time in partial load mode - The temperature at the boiler inlet must not be less than 65°C, boiler water temperature must be between 80°C and 85°C. - Use the boiler for a short period to heat warm water in the summer.

9. OPERATION OF BOILER

-User's training for operation and maintenance of boiler is performed by an authorized installer.



Failure to observe the installation and operating requirements described in the manual and the service booklet voids the warranty.



Protective gloves must be used

9.1. Operation of boiler Pell Easy

Ignition.

After starting the boiler up from the control panel, the main pellet auger conveys certain amount of fuel in Combustion chamber. This specific amount of pellets is set by the installer and depends on the fuel characteristics. This specific amount of pellets is being ignited using hot air.

Burning.

The burning process takes place in the combustion chamber of the boiler, as the fuel portions are dosed (measured) at regular intervals by the integrated auger. This achieves optimum combustion. The boiler performance is controlled and operated by a temperature sensor that measures the temperature of the water jacket (mantle) and a temperature sensor that measures the temperature of the exhaust gases. Ignition and stop are controlled by the exhaust gas sensor, which gives information to the control unit. The power is determined by the adjusted maximum temperature in the boiler, as shortly before reaching it, it starts modulating.

Self cleaning system.

The boiler has a self-cleaning feature that allows self-cleaning of the combustion chamber. At regular intervals, the fan starts on maximum power to clear the residual ash in the combustion chamber. Thus ensuring a long and effective combustion process.

9.2. Important recommendations for long-lasting and correct operation of the boiler

- For assembly and installation of the boiler follow the requirements in this manual.
- Use only recommended in this manual fuel.
- Use only recommended in this manual Combustion chamber before clean it. Depending on fuel and burner settings, clean the pellet burner once a week.
- User's training for operation and maintenance of boiler is performed by an authorized installer or service shop.

	Failure to observe the installation and operating requirements described in the manual and the service booklet voids the warranty.
--	---

9.3. Requirements for the cleaning and maintenance of Pell Easy pellet boiler.

	Attention! Important instructions regarding cleaning of boiler
--	---

	Caution! Hot surfaces. Before cleaning the boiler, make sure the fire in it has died out and the boiler has cooled down.
--	---

Cleaning the ash from the ash container once a week is a must. It is done by removing the two wing nuts, laying on the both sides of the ash container. Pull the ash container and clean it. After it is empty and clean, make sure it is positioned well and screw up the wing nuts again. Clamp them manually till it's not possible anymore..

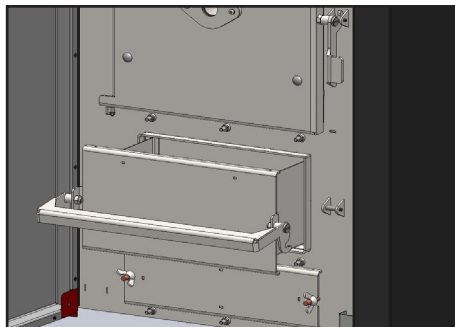

Diagram 9

It is mandatory cleaning combustion chamber of the burner fnce every 2-3 dat to once week, depending on the use an the fuel type.

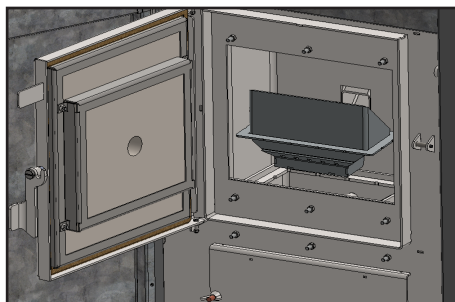

Diagram 10

	Attention! Cleaning and maintenance of the boiler should be carried out only by an authorised installer/service shop.
--	--

Before the start of the heating season it is mandatory to check and clean the following components of the boiler:

9.3.1 Cleaning and maintenance of suction fan

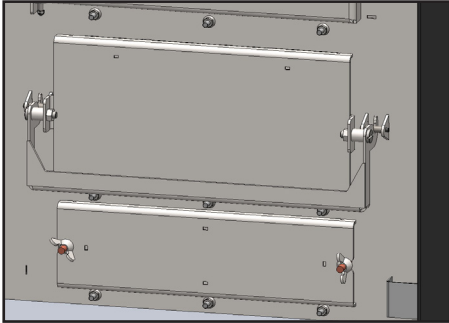

Diagram 11

Unmount the ash container as described in the manual instruction.

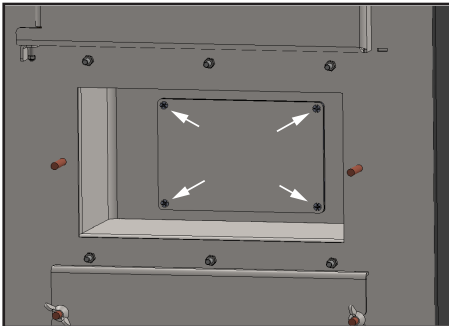

Diagram 12

Unmount by using the “+” screwdriver the four screws size M5. After that unmounts the revision cover.



Attention! Make sure that no flaming and smoldering pellets go clean with a vacuum cleaner and temperature surfaces is less than 40 °C

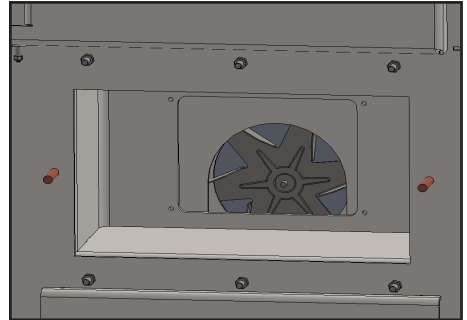

Diagram 13

After the revision cover is unmounted, there is direct access to the fan turbine. Do detailed cleaning by using brush and vacuum cleaner of the ash on the fan turbine as well as the zone around it. After the zone is well cleaned, put the revision cover back and clamp well the four screws size M5.

9.3.2 Cleaning and maintenance of the Fume exhaust tube

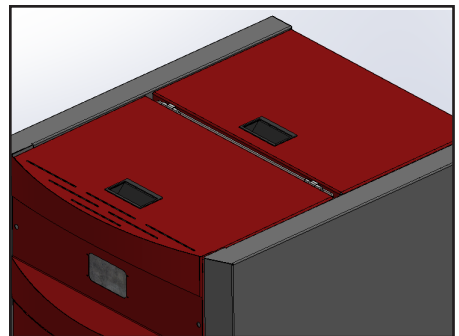

Diagram 14

-Open the front revision cover, pointed in scheme 14.

- The inner revision cover is fixed with four "ear" nuts (2 on each side, pointed in scheme 14). Unmount them to loose the cover.

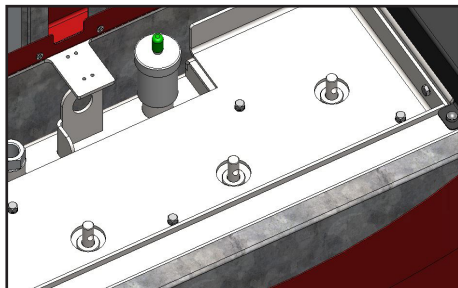

Diagram 15

- Pull up carefully the revision cover altogether with resistance spirals. Remove the cover from the boiler.

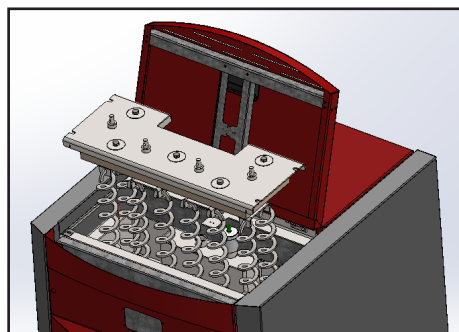

Diagram 16

- After the revision cover is removed, clean well the ash over the pipes and the inner surface of the boiler by using brush and vacuum cleaner. Make sure that the lower pipe parts on the bottom are also well cleaned, as it is the most ash collecting part.

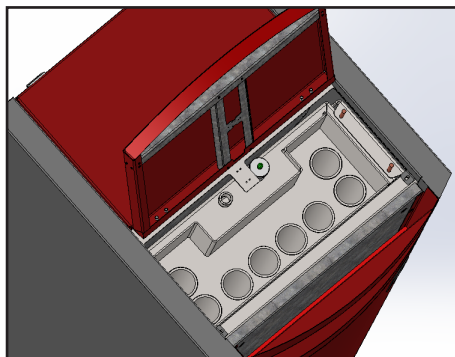
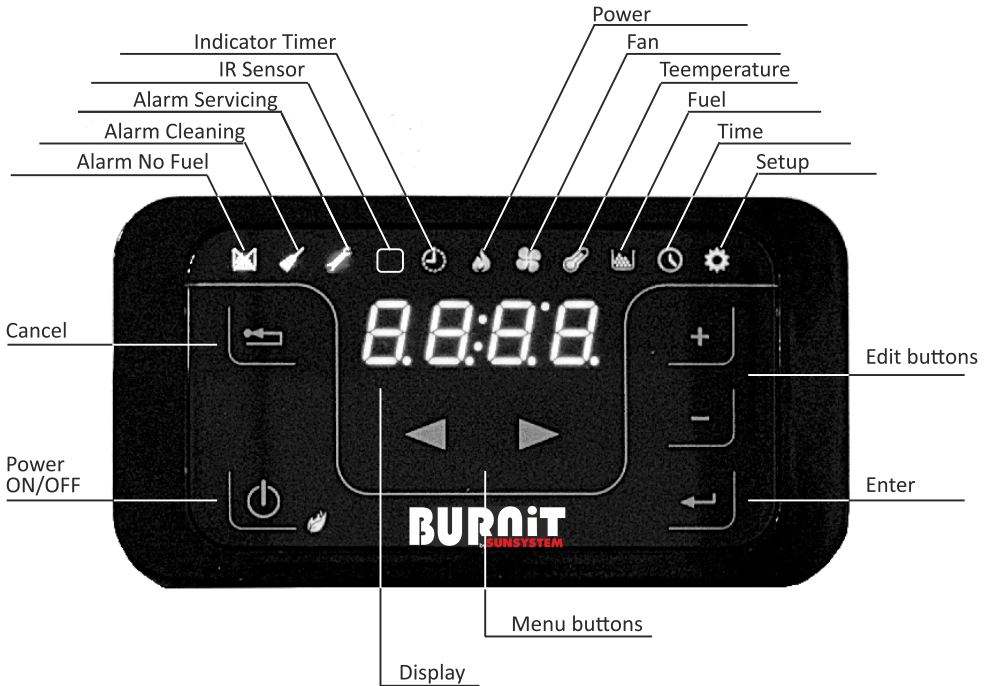

Diagram 17

10. MICROPROCESSOR CONTROLLER

10.1. Explanation of Symbols.



10.2. Controller Menus

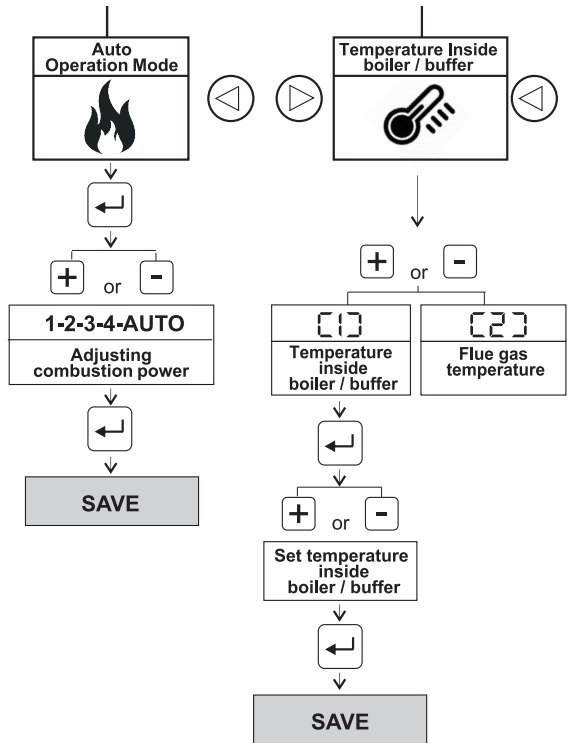

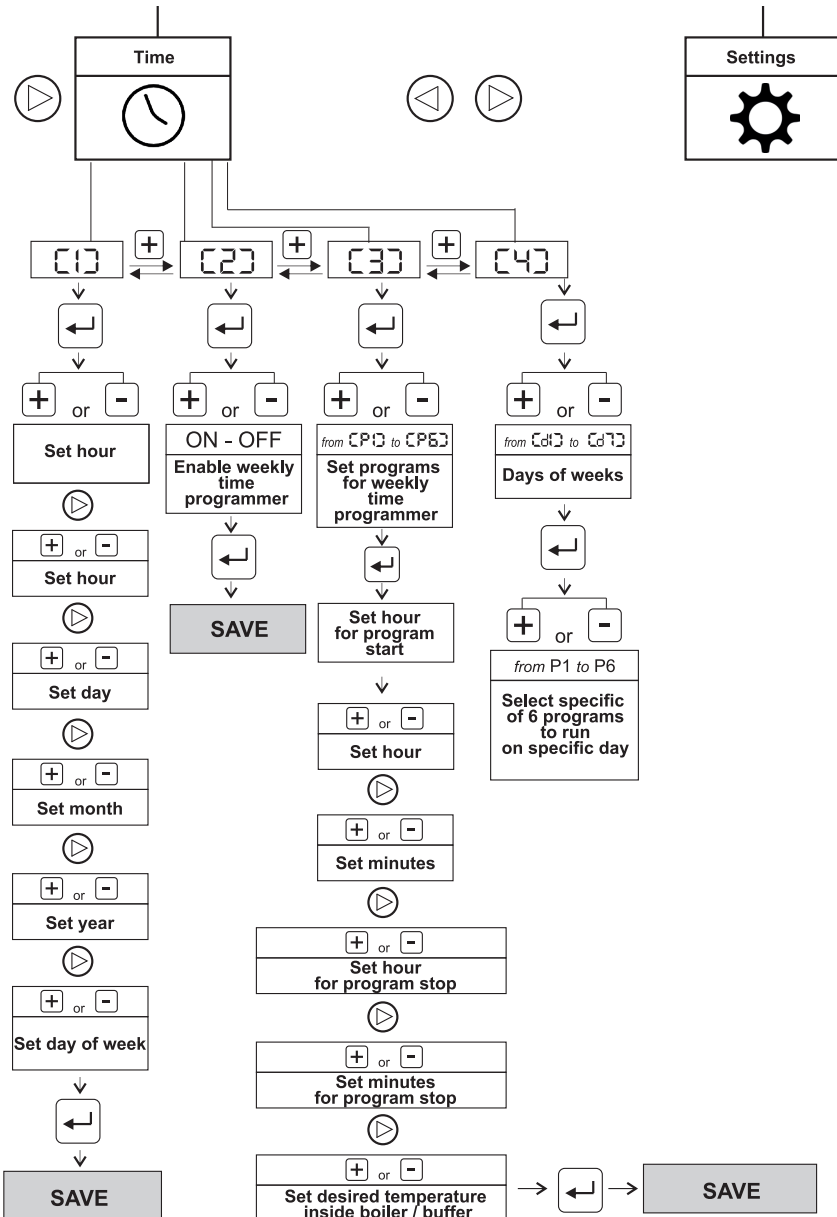

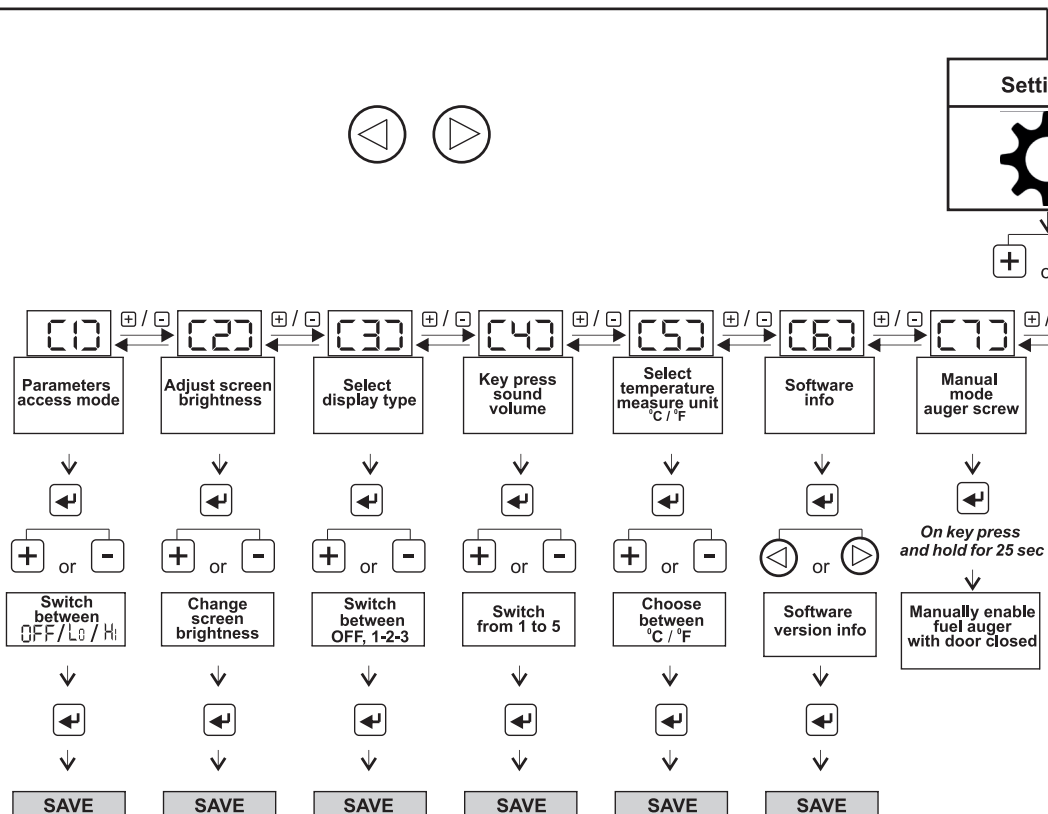

★ On the display you will see a random generated number between 1 and 9 .
 These numbers are different every time. Sum all four numbers and add "1" to the result.
Example - sum result is 25 + 1 = 26
 Enter the code as described.

- ★ ★
- S: 00 - №. of heater starts
 - S: 01 - Boiler overheat
 - S: 02 - Ignition fail
 - S: 03 - Total runtime
 - S: 04 - Total burning time
 - S: 05 - Cleaning time
 - S: 06 - Restart service timer

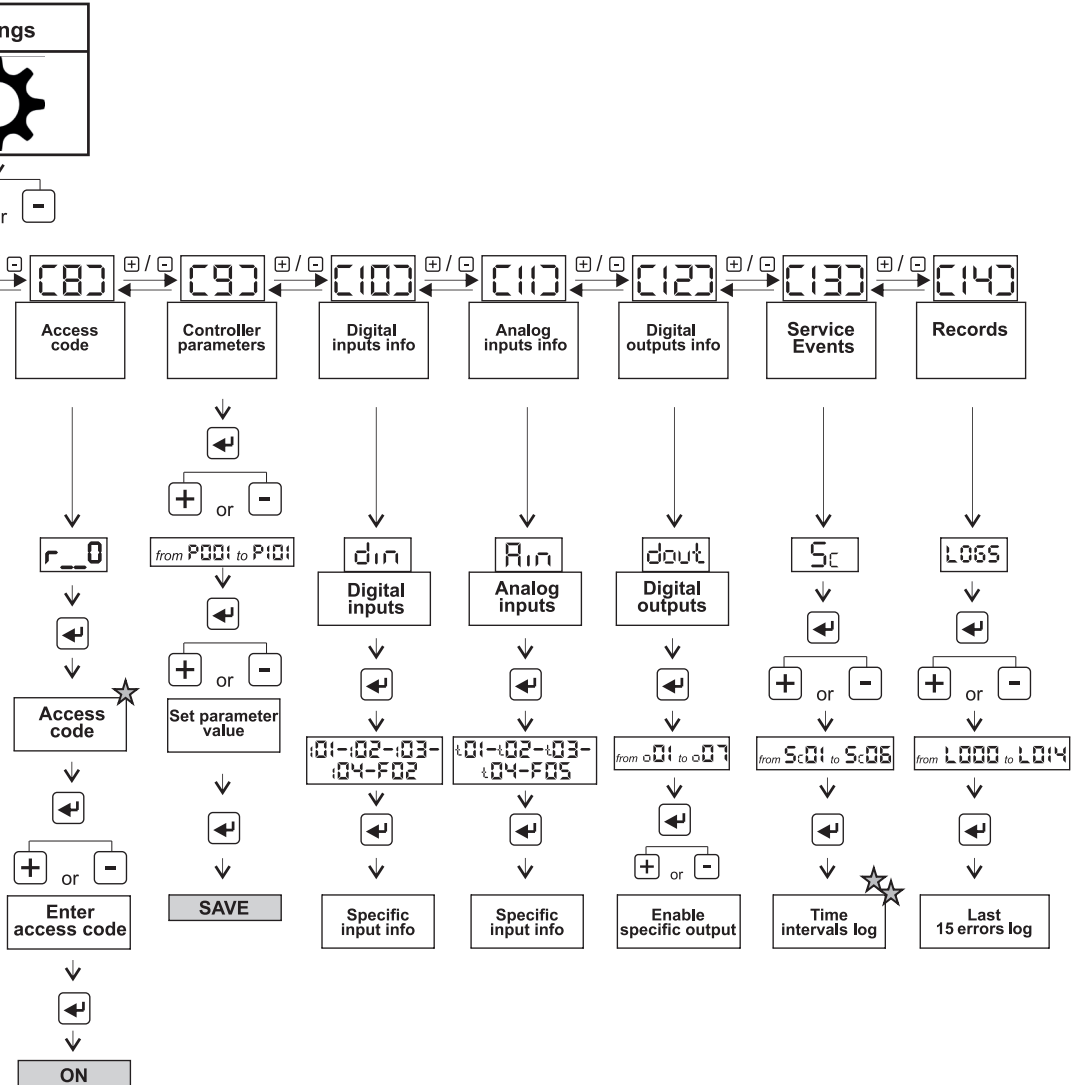

Table 7
Possible error codes

















Displayed on controller screen	Code	Problem causes	Problem solution
“No fuel” icon is on 	----	Appears upon lack of fuel	<i>Fill up the fuel bunker. Restart controller from the ON/OFF key.</i>
“Cleaning” icon flashes 	A003	Firebox or flue are polluted and need cleaning. Excess ash or unburned fuel in the firebox.	<i>Check and clean the firebox or contact your installer to clean the flue.</i>
“Cleaning” icon is on 	----		
Икона “Сервиз” премига 	A004	Controller battery low on charge	<i>Contact your service for replacement.</i>
Икона “Сервиз” премига 	A005	Fan encoder fault	<i>Contact your service.</i>
Икона “Сервиз” премига 	A007	Boiler door open longer than 1 minute in operation mode	<i>Close the door and restart the boiler from the ON/OFF key.</i>
“Service” Icon is on 	E001	Display screen error	<i>Contact your service.</i>
“Service” Icon is on 	E004	Display-controller communication error	<i>Contact your service.</i>
“Service” Icon is on 	E101	Ignition failed, high temperature in the water jacket of the boiler	<i>Contact your service.</i>
“Service” Icon is on 	E102	The chimney, the intake air pipe or the boiler burner are blocked.	<i>Contact your service.</i>
“Service” Icon is on 	E106	Defective or non-contacting buffer sensor.	<i>Contact your service.</i>
“Service” Icon is on 	E108	Overheating of the boiler or back burning.	<i>Restart the STB thermostat on the rear panel.</i>
“Service” Icon is on 	E109	Open door sensor error	<i>Contact your service.</i>
“Service” Icon is on 	E110	The room temperature sensor is defective / not connected.	<i>Contact your service.</i>
“Service” Icon is on 	E111	The exhaust sensor is defective / not connected.	<i>Contact your service.</i>
“Service” Icon is on 	E113	Excessively high exhaust temperature. Boiler cleaning is required.	<i>Contact your service.</i>
“Service” Icon is on 	E114	Ignition failed. Check the fuel level.	<i>Contact your service.</i>

Table 8
Controller Settings

Parameter code	Explanations	Measure units	Values Pell Easy 20	Values Pell Easy 35/35 XL
P 000	Maximum waiting time for successful firing in the ignition phase.	minutes	30	30
P 001	Maximum time for flame detection with igniter off in the Test Fire sequence.	minutes	10	10
P 003	Auger pause during heat up.	seconds : 10	70	75
P 004	Auger work during heat up.	seconds : 10	30	25
P 005	Auger pause during the Fuel ignition sequence.	seconds : 10	65	80
P 006	Auger work during the Fuel ignition sequence.	seconds : 10	35	20
P 007	Auger pause during the ignition Test sequence.	seconds : 10	65	80
P 008	Auger work during the ignition Test sequence.	seconds : 10	35	25
P 010	Auger work at minimum power level.	seconds : 10	13	14
P 018	Auger work at maximum power level.	seconds : 10	55	45
P 019	Fan speed at shutdown.	-	220	240
P 020	Fan speed at combustion check-up.	-	38	65
P 021	Fan speed during Heat Up sequence.	-	40	106
P 022	Fan speed in the Fuel ignition sequence.	-	45	115
P 023	Fan speed in the ignition Test sequence.	-	50	120
P 024	Fan speed at first power level.	-	35	130
P 028	Fan speed at maximum power level.	-	65	155
P 050	Temperature difference for boiler start-up upon reach of maximum temperature	°C	5	5
P 051	Maximum temperature inside boiler. * In "boiler with buffer" mode, this parameter is calculated as (PAR 84 + PAR 86) and cannot be changed manually.	°C	75	60

Parameter code	Explanations	Measure units	Values Pell Easy 20	Values Pell Easy 35/35 XL
P 053	<i>Boiler stop temperature.</i>	°C	5	5
P 054	<i>Flue gas temperature to switch controller into combustion check-up.</i>	°C	60	52
P 055	<i>Gases modulation start the temperature.</i>	°C x 2	85	85
P 056	<i>Flue gas temperature to stop fan during boiler shutdown.</i>	°C	55	55
P 057	<i>Maximum flue gas temperature to trigger boiler shutdown.</i>	°C x 2	95	95
P 059	<i>"No fuel" alarm trigger temperature of Flue gas.</i>	°C	53	51
P 060	<i>Period between two self-cleaning during combustion.</i>	minutes	30	20
P 061	<i>Duration of the self-cleaning during combustion.</i>	seconds	30	30
P 062	<i>Fan speed during cleaning.</i>	-	115	185
P 067	<i>Temperature in boiler of start of the circulating pump.</i>	°C	50	45
P 068	<i>Temperature in boiler of stop of the circulating pump.</i>	°C	40	40
P 070	<i>Heat up sequence duration.</i>	seconds	150	120
P 076	<i>Choice of configuration (1-working depends Buffer temperature; 2-working depends Boiler temperature)</i>	-	1	1
P 082	<i>Minimum value of air flow the occurrence of an error</i>	-	100	100
P 083	<i>Time after which occurs upon decrease of alarm airflow</i>	seconds	60	30
P 084	<i>Maximum temperature in the buffer</i>	°C	75	75
P 086	<i>Minimum temperature difference between the boiler and the temperature in the buffer.</i>	°C	5	5
P 094	<i>Time to display the service message.</i>	days	0	0
P 101	<i>Time to clean the boiler after extinguishing.</i>	seconds	180	210

Table 9.

Table
For operation and services of pellet boiler Pell Easy

PARTS / INTERVAL	1 - 2 DAYS	EVERY WEEK	15 DAYS	60-90 DAYS	EVERY SEASON
Clean the burner *	•				
Clean the ash collection compartment with a vacuum cleaner		•			
Clean the ash pan	•				
Clean the hearth door and glass			•		
Clean the turbulators	•				
Clean the lower ash pan			•		
Clean the "T" exhaust fittings (outside the boiler)				•	
Clean the exchangers and remove ash incrustation					•
Clean the chimney					•
Circulation pump inspection					•
Hudraulic leaks inspection					•
Door dasket inspection					•
Start-up spark plug inspection					•
Door clousure operation					•

* **With poor quality pellets cleaning frequency must be increased.**

11. CONNECTING WI-FI MODULE TO THE PELL BOILER

Attention! Exposure to water and other liquids.

Do not expose the product to water, detergents, solvents or other liquids, as this may damage the electronics or cause malfunctions.

When using the product, avoid contact with water or other liquids.

Cleaning.

The **BURNIT** does not require special cleaning. However, if you clean, use a dry cloth carefully to wipe the module.

11.1. Downloading the BURNIT app.

The newest version of **Burnit app** is always available for download at **Google Play** (for Android based devices) and **App Store** (for iOS based devices). You can download the app by typing exactly "Burnit " in the search window of your smart device (smart phone or tablet).

11.2. Installation of WI-FI module.

Follow the procedure steps exactly as they are written :

Step 1

- Disconnect the electrical cable of the Pell Boiler from the electrical supply.

Step 2

- Disconnect the display cable from the controller at the back of the boiler.

Step 3

- Connect the splitter instead.

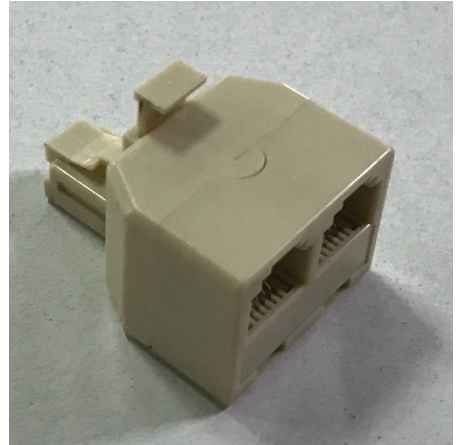

Splitter

Step 4

- In one of the sockets (it doesn't matter which one) of the splitter reconnect the display cable again.

Step 5 (see the scheme)

- Connect the Wi-Fi module to the electrical supply.

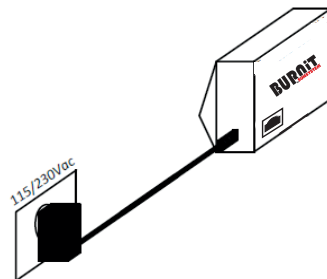

Step 6

- Connect your smart device with Wi-Fi network with internet access, which the Wi-Fi module will work with.

Step 7

- Start the "Burnit" app. Read and accept the user agreement.

Step 8

- The app will show you a window - „ **Have you already connected the heating device to your Wi-Fi** „ - choose „ **NO**“.



Step 9

-A new window will open in the app, which shows you to press the "Setup WiFi reset" button on the module. After this the module starts searching for a network and the "WiFi" light on the module starts blinking fast.



Step 10

- Go at the WiFi networks list in the settings of your smart device and choose the network "WIRCU-XXXXXX". Go back in the app and choose "next".

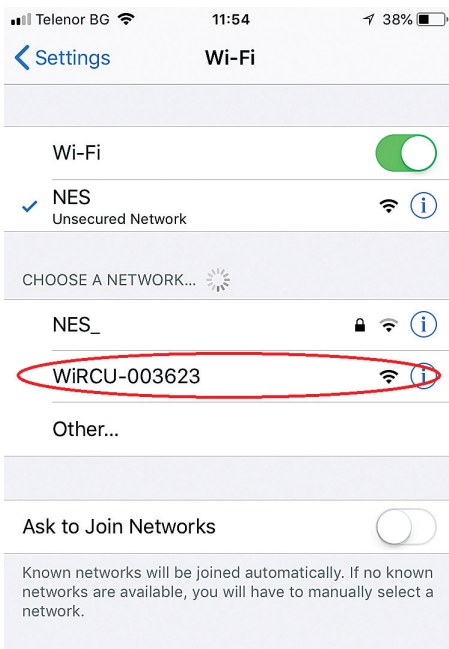

Step 11

- In the app choose the Wifi network which is connected with your smart device and type the password (in case you don't use password don't type anything).

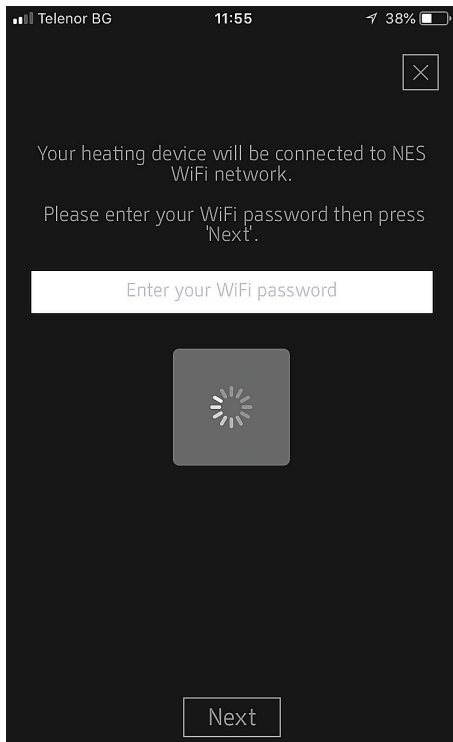
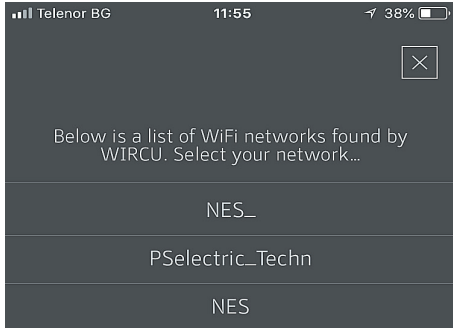
**Step 12**

- Now you have successfully connected the WiFi module with internet. After this disconnect the module from the electrical supply and reconnect it again. When you finish the procedure the "WiFi" and "status" lights on the module must be on. Back in the app choose "Done".

**Step 13**

- Connect the module and the splitter by a cable found in the box set. Use the second socket of the splitter.

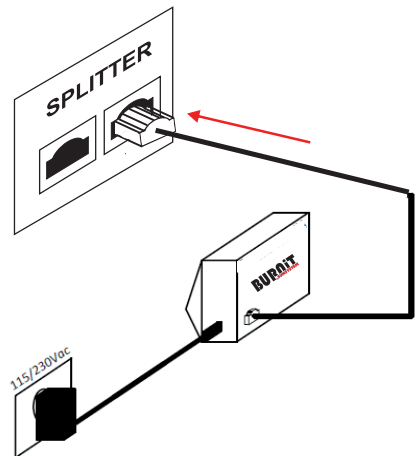

Step 14

- Reconnect the Pell Boiler to the electrical supply. Than the third light of the module - "cont" must be on.



Step 15

- Go back in the app and type the MAC address and the PIN code, which can be found written on the card from the box set or on the WiFi module. Your smart device is now connected to the boiler.

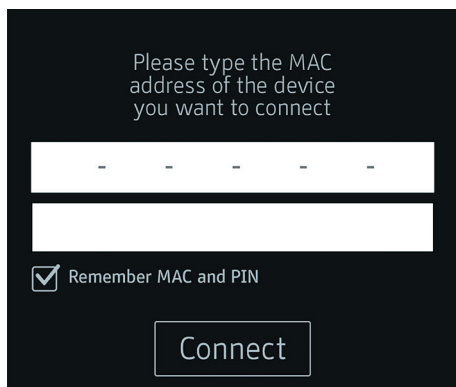
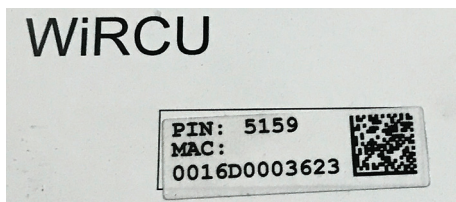

11.3. "Burnit" app abilities : After your smart device is already connected with the boiler.



With "+" и "-" you can adjust the temperature, you want the boiler to maintain. At the bottom right of the screen is the timer button from which you can set the boiler to start heating after specific hours.

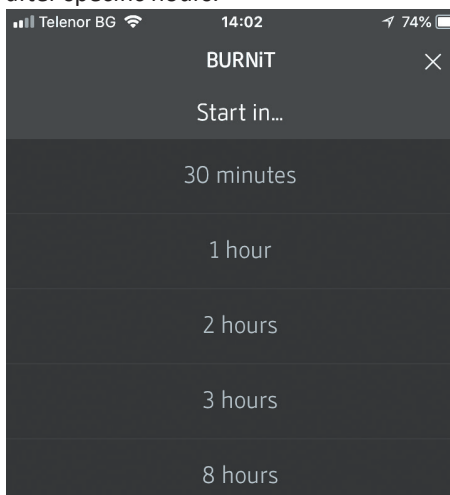

It also has the option to start in exact days, hours and minutes:

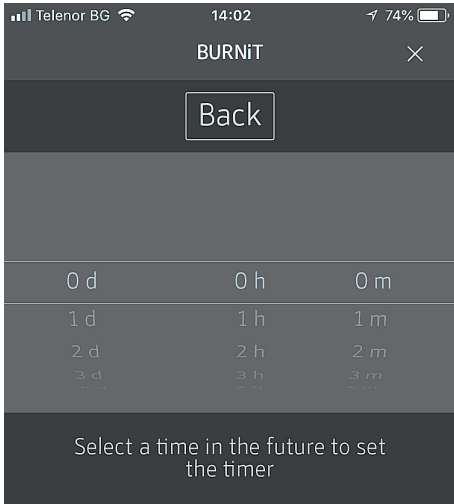
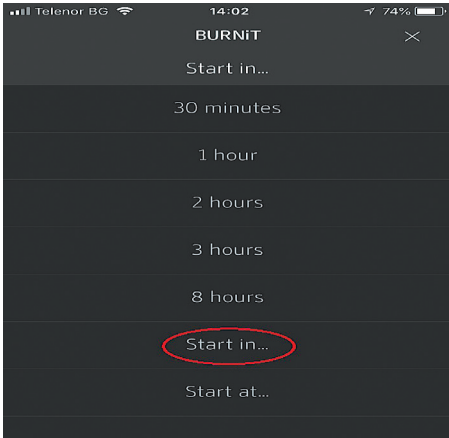

Or you can set the timer to start on a specific date:

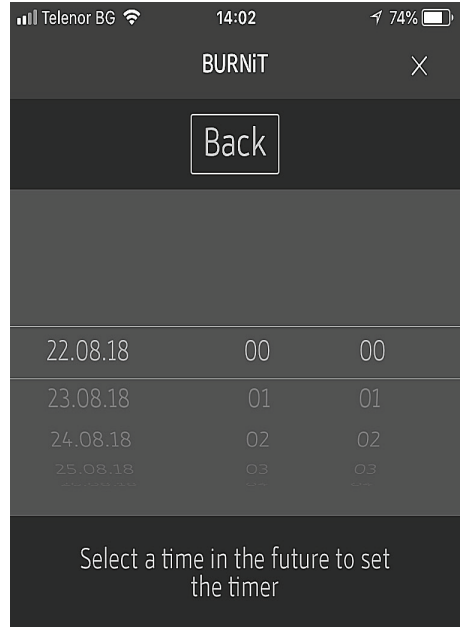

At the start window in the top left there is a button which shows you more options. Again with "+" и "-" you can adjust the working power of the boiler.

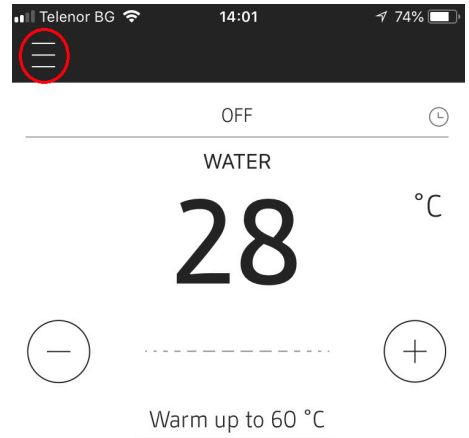

In “**settings**” you can adjust the language of the app, the notifications and the temperature unit.

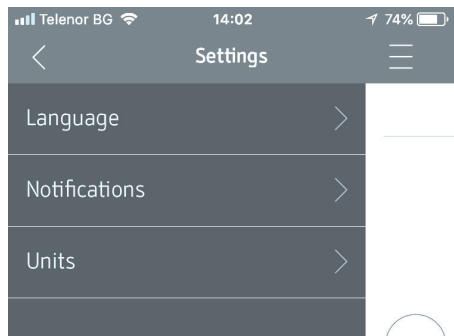
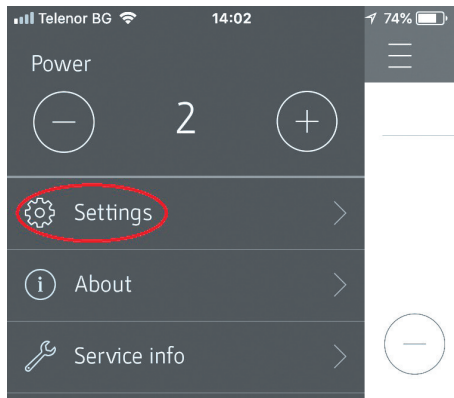

1. App Language

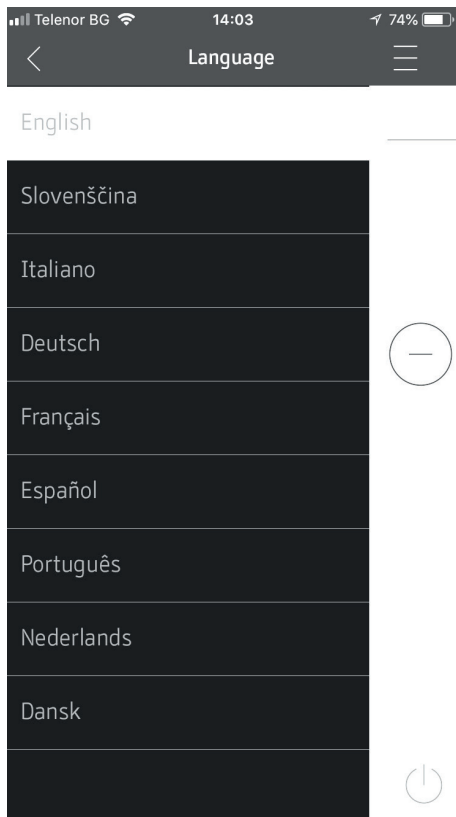
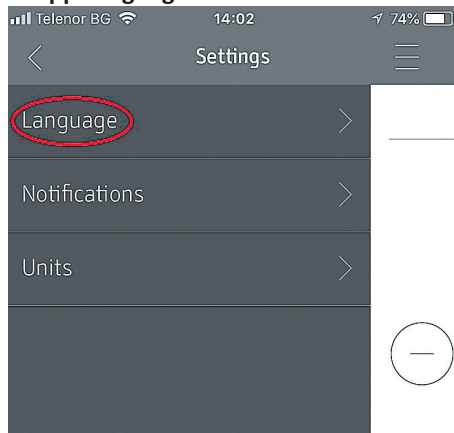

2. Notifications

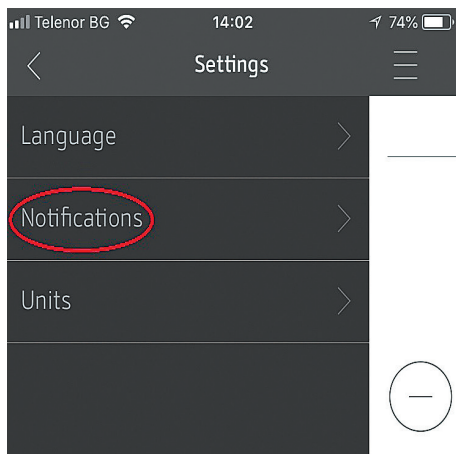

3. Temperature units.

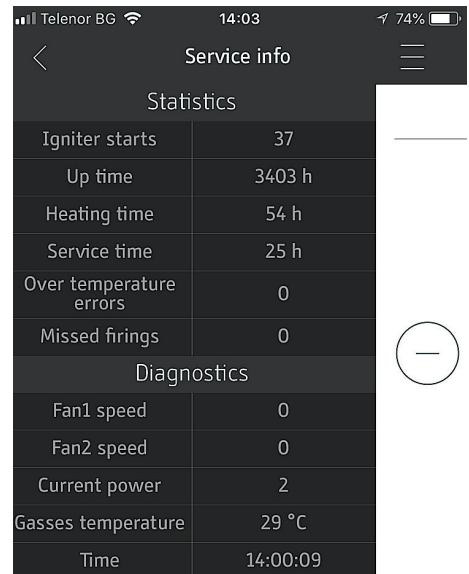
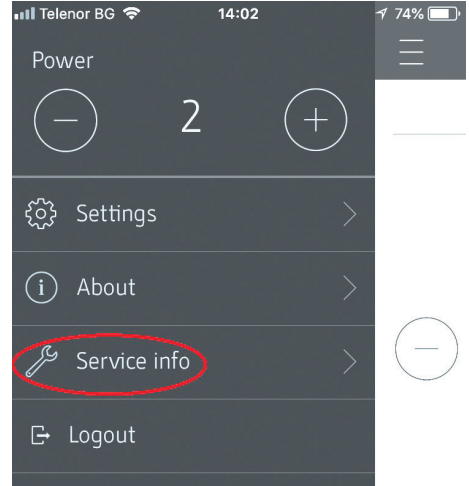
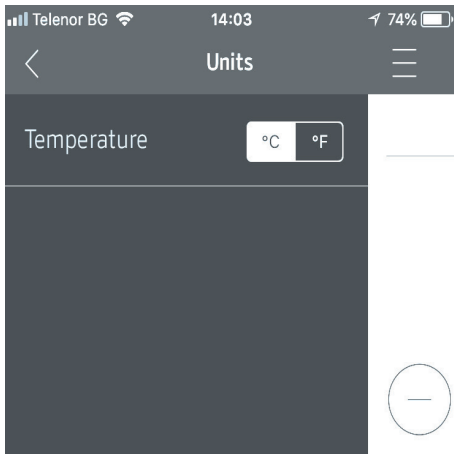
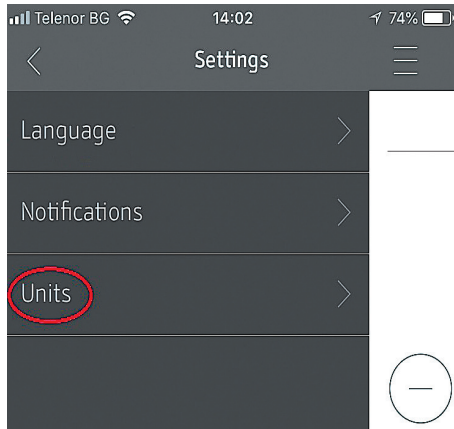

From the service info button you can see information about the boiler - number of starts, working hours, heating hours, service hours, over temperature errors, adjusted power, time and more.

12. WARRANTY TERMS

The warranty terms are described in the Service booklet included in the supply

13. TECHNICAL FEATURES

13.1. Technical features of Pell Easy pellet boiler

13.1.1. Elements of Pell Easy pellet boiler

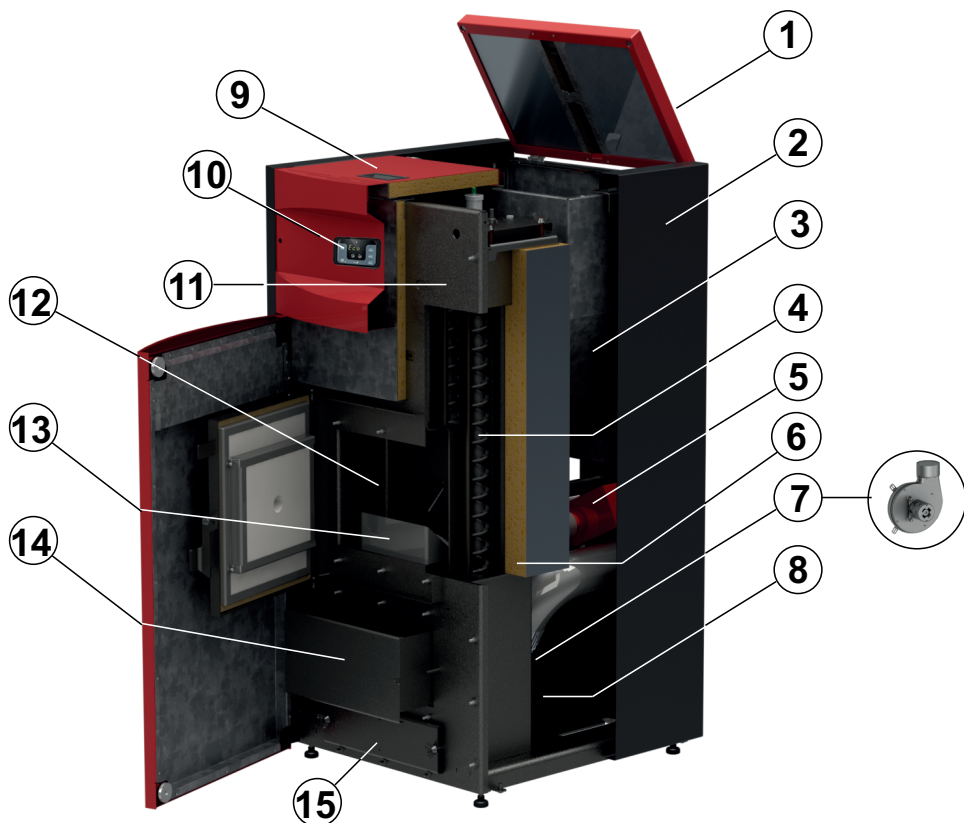



- | | |
|---------------------------------------|-------------------------|
| 1. Cover for fuel filling | 11. Water mantle |
| 2. Housing | 12. Combustion chamber |
| 3. Built in fuel hopper | 13. Burner |
| 4. Fume exhaust tube with turbulators | 14. Container for ashes |
| 5. Pump | 15. Inspection opening |
| 6. High efficiency thermal insulation | 16. Hot water outlet |
| 7. Fume exhaust fan of the boiler | 17. Cold water inlet |
| 8. Expansion vessel | 18. Flue |
| 9. Revision plate | 19. Sleeve for drain |
| 10. Microprocessor controller | 20. Incoming air pipe |

Diagram 20. Elements of Pell Easy pellet boiler

13.2. Technical parameters of Pell Easy pellet boiler

		Pell Easy 20	Pell Easy 35	Pell Easy 35 XL
Max heat output	kW	18	29	29
Min. / Nominal heat output	KW	5.1÷16.3	8.7÷29	8.7÷29
Height H	mm	1260 ± 15	1260 ± 15	1260 ± 15
Width L / Depth D	mm	625/790	770/870	1100/770
Water mantle volume	L	35	45	45
Combustion chamber volume	L	12	14.6	14.6
Required chimney draught	Pa/mbar	8/0.8	17/0.17	17/0.17
Insulation	Boiler	100 mm high-efficiency thermal wool lined with aluminum foil 50 mm vermiculite		
	Door			
Power consumption: maximum / minimum	W	410/42	410/42	410/42
Power consumption of circulation pump	W	5÷40	5÷40	5÷40
Electric power supply	V/Hz/A	230/50/2	230/50/2	230/50/2
Recommended fuel	wood-pellets, diameter 6÷8 mm EN ISO 17225-2:2014			
Exhaust gas temperature (operation mode)	°C	100÷120	72÷120	72÷120
Mass flow of exhaust gases, Minimum ÷ Maximum heat output	kg/s	0,0045 ÷ 0,01	0,0182 ÷ 0,0077	0,0182 ÷ 0,0077
Operating temperature range	°C	55-85	55-85	55-85
Minimum return water temperature	°C	45	45	45
Operating pressure	bar	3	3	3
Weight	kg	252	347	370
Capacity of Pellet fuel hopper	L	75	90	225
Cold water inlet	A, mm	R1"/485	R1"/485	R1"/485
Hot water outlet	B, mm	R1"/570	R1"/560	R1"/560
Sleeve for drain / safety valve	C, mm	R¾"/500	R¾"/500	R¾"/500
Incoming air pipe	E, mm	ø76/400	ø76/400	ø76/400
Flue	F, ø /mm	ø100/370	ø100/420	ø100/420
Air vent	G	✓	✓	✓
Sleeve for sensor	K	✓	✓	✓
Manual cleaning system	L1	✓	✓	✓
Igniter	M	✓	✓	✓
Pellet burner	N	✓	✓	✓
Inspection opening	O, mm	65/290	2 x (85/230)	2 x (85/230)
Circulation pump	P	✓	✓	✓
Expansion vessel	R, liters	6	8	8
Fuel hopper for wood-pellets	S	✓	✓	✓
Microprocessor controller	U	✓	✓	✓
Eyepiece for viewing the combustion process	V	✓	✓	✓

Fume exhaust fan of the boiler	W	✓	✓	✓
Ash-and-soot container	X	✓	✓	✓
Inspection hatch	Y	✓	✓	✓
Top loading hatch of fuel hopper	Z	✓	✓	✓
Boiler class according to EN 303-5/2012 r.		class 5	class 5	class 5
Fuel period at nominal power - Qn	h	13	21.5	21.5
El. consumption in mode "Stand by Power"	W	3	3	3

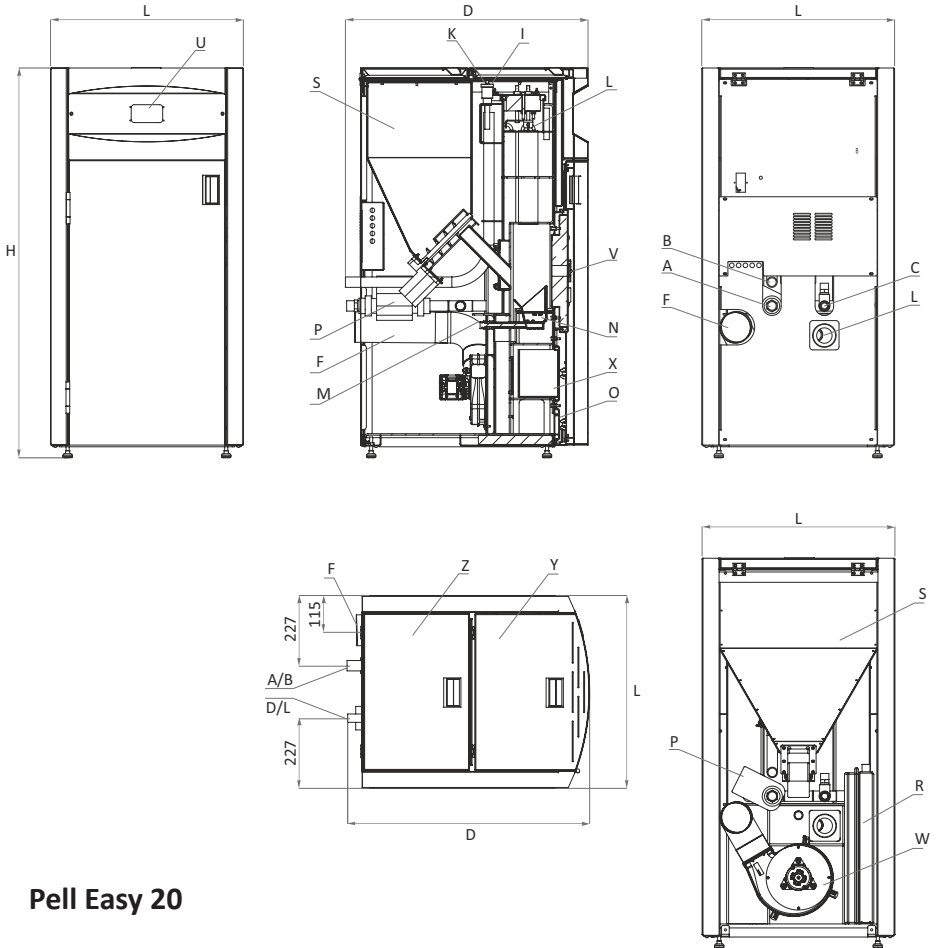

Pell Easy 20

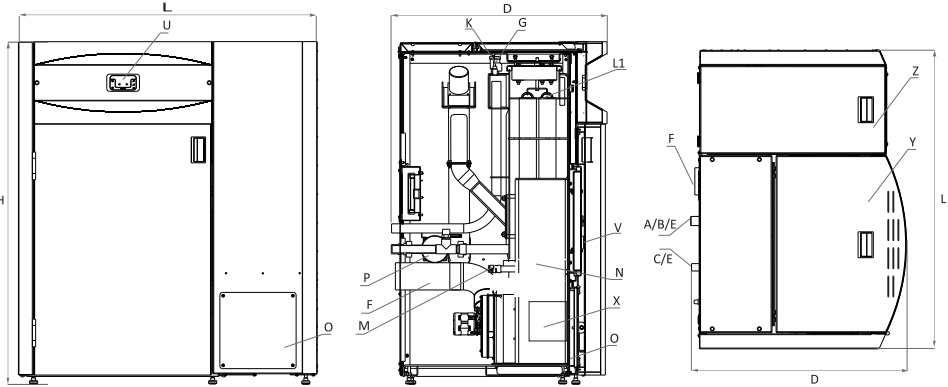

Pell Easy 35 XL

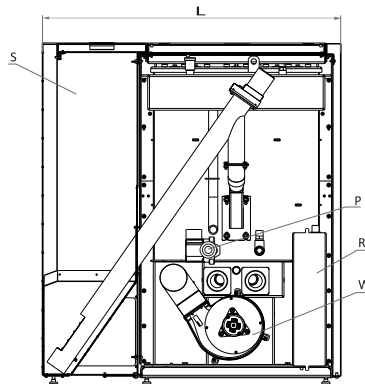
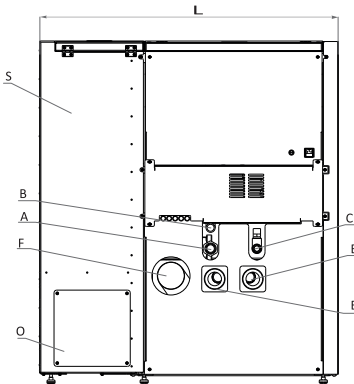

14. RECYCLING

Submit all packaging material for recycling according to the local regulations and requirements.

At the end of life cycle of each product its components are due to be disposed of in conformity with regulatory prescriptions. Obsolete equipment shall be collected separately from other recyclable waste containing materials with adverse effect on health and environment.

According to Directive 2002/96/EC regarding electrical and electronic equipment waste, disposal thereof is required separately from the normal flow of solid household waste.

Expired appliances must be collected separately from other recyclable waste containing substances hazardous to health and environment. Both metal and non-metal parts are sold out to licensed organizations for recyclable metal or non-metal waste collection. In any case they should not be treated as household waste.





NES Ltd. **new energy systems**

tel.: +359 700 17 343
www.burnit.bg